

POINT TABLE			POINT TABLE		
POINT #	NORTHING	EASTING	POINT #	NORTHING	EASTING
1	10656304.8035	402123.3985	15	10656221.2886	402669.7954
2	10656333.8388	402125.0417	16	10656188.7539	402652.1976
3	10656344.6135	402137.1698	17	10656187.8165	402667.7952
4	10656342.9602	402166.3840	18	10656207.7878	402668.9863
5	10656331.7515	402187.0751	19	10656240.1266	402690.8936
6	10656323.3674	402314.6673	20	10656239.8293	402696.1464
7	10656342.7990	402346.3620	21	10656272.2853	402697.9832
8	10656341.0052	402375.1458	22	10656207.4575	402674.4854
9	10656318.3787	402402.7256	23	10656187.4743	402673.2869
10	10656307.7616	402617.3120	24	10656290.7087	402913.8863
11	10656341.1445	402646.0434	25	10656317.9227	402944.4726
12	10656339.2927	402676.7352	26	10656316.9629	402960.4438
13	10656302.8298	402699.7118	27	10656257.6333	402956.6783
14	10656274.5846	402657.3558			

NEW CONSTRUCTION SUMMARY DELTA DRIVE FROM STA. 0+00 TO 7+50				
NO.	ITEM	STATION	ASBUILT	QUANTITY
3	8" PVC (CLASS 305) WATERLINE			146 LF
5	12" PVC (CLASS 305) WATERLINE			716 LF
7	TRENCH SAFETY SYSTEM			864 LF
16	4-SACK SOIL CEMENT BACKFILL & SUBGRADE			576 SY
20	2" HMAc PAVEMENT REPLACEMENT (BRIDGE)			576 SY
21	2" MILL AND OVERLAY EXISTING HMAc BEYOND BRIDGE			2832 SY
23	REMOVE & REPLACE CONCRETE SIDEWALK			101 SF
24	REMOVE & REPLACE CURB & GUTTER			20 LF
26	CONCRETE APRON FOR PAVEMENT PENETRATIONS			7 EA

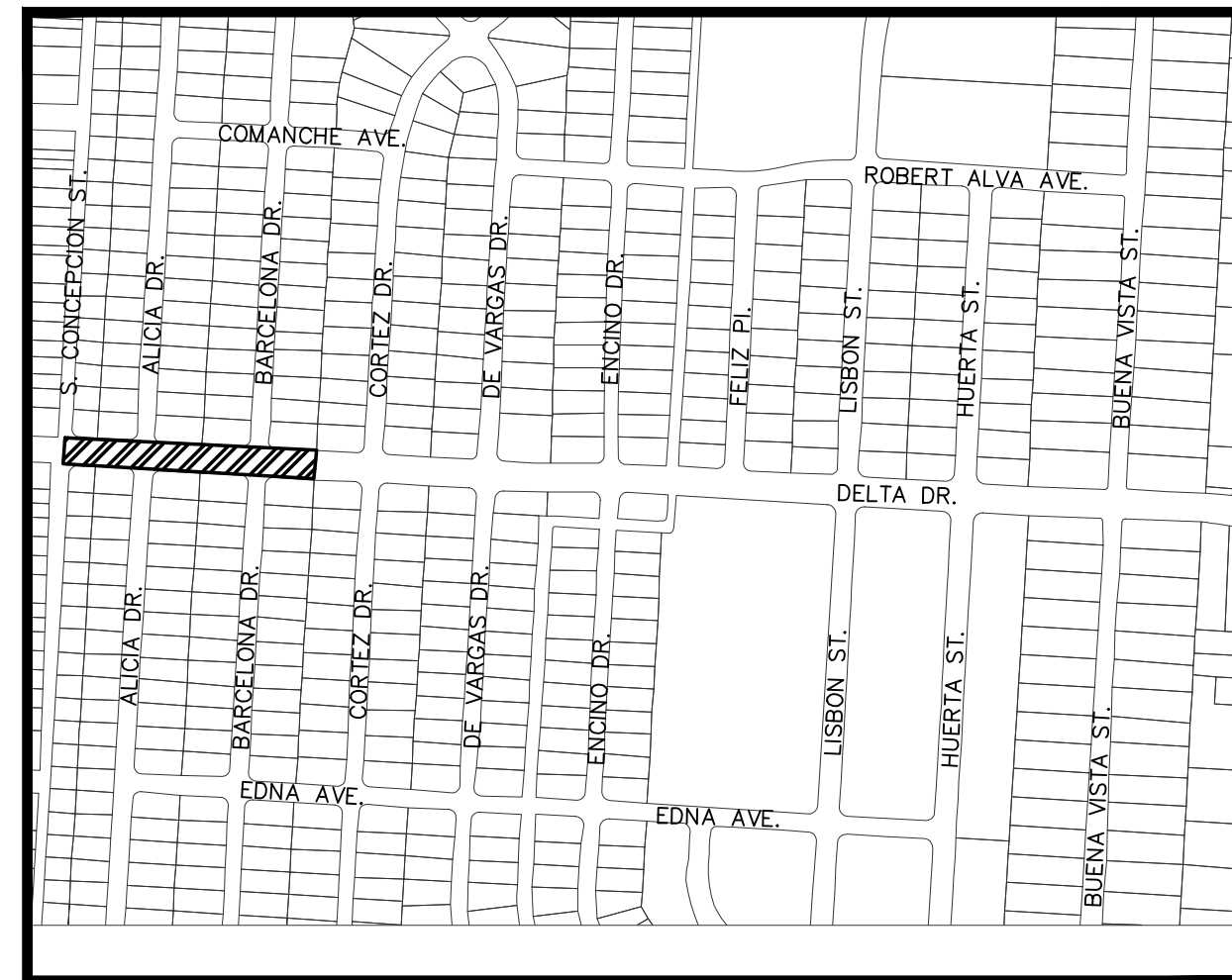
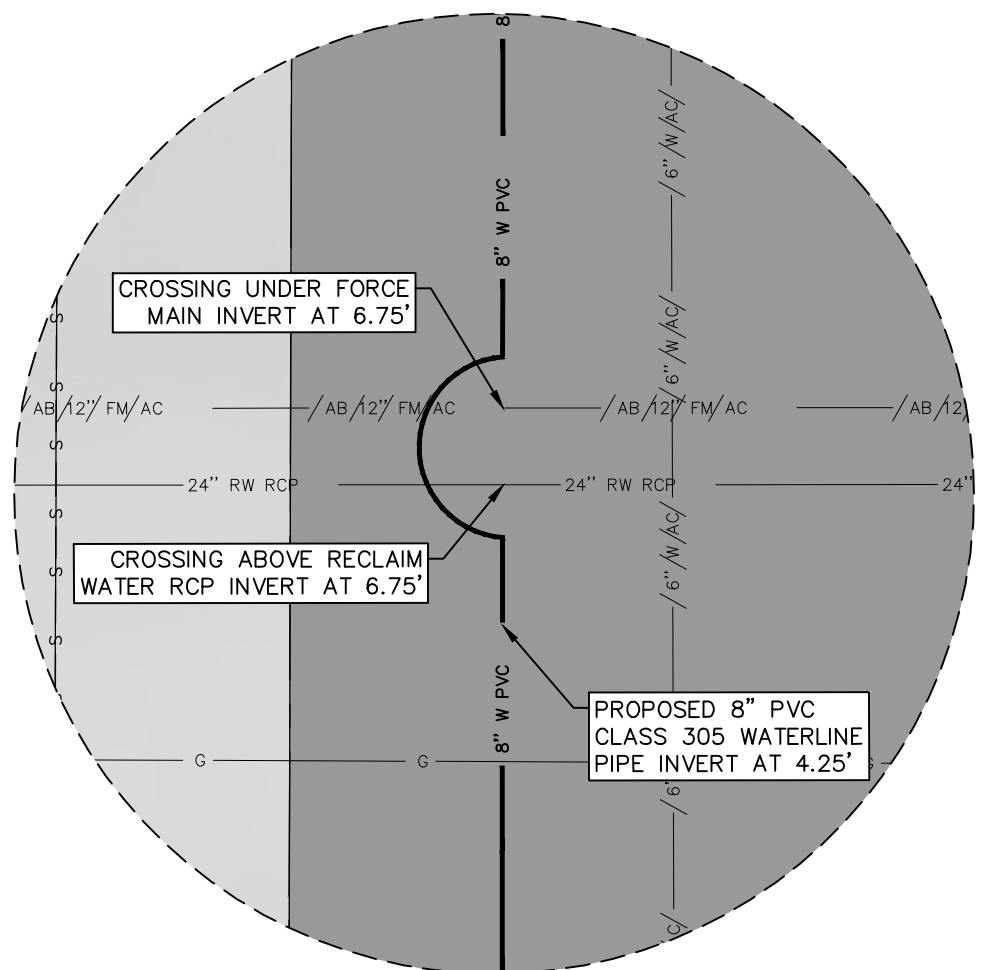
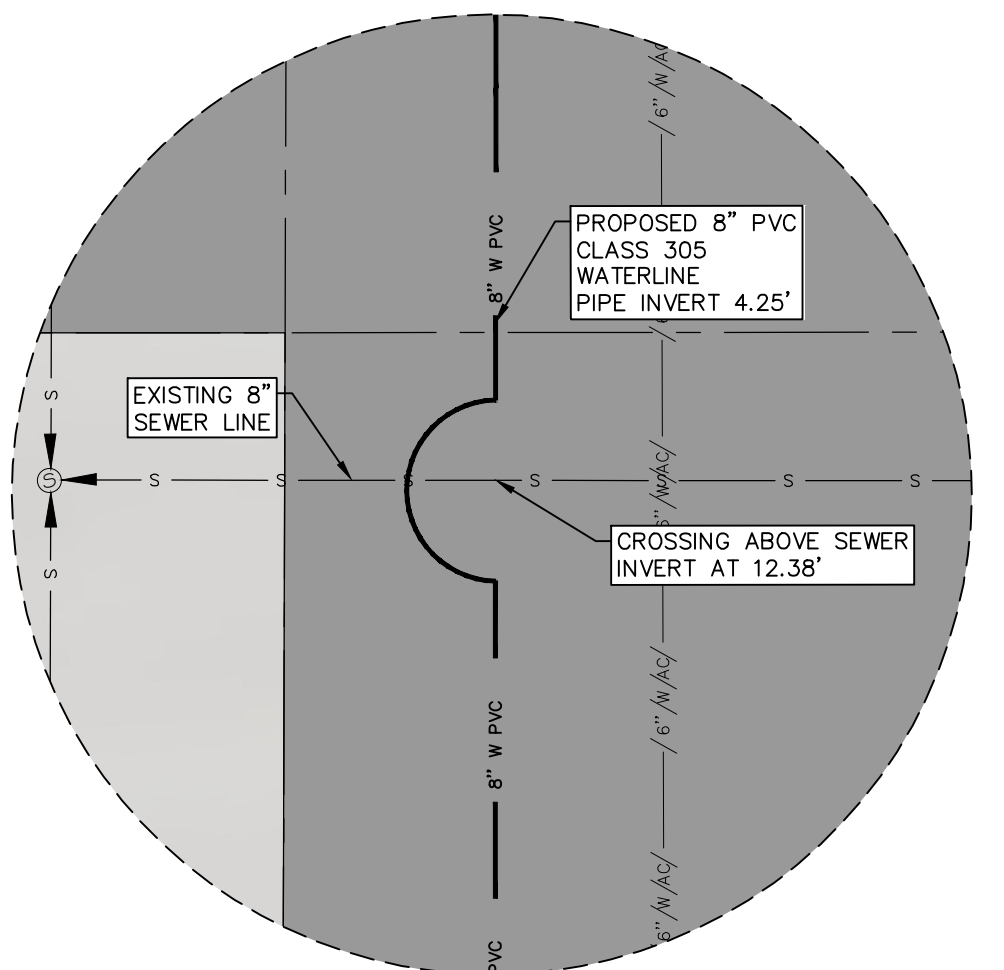
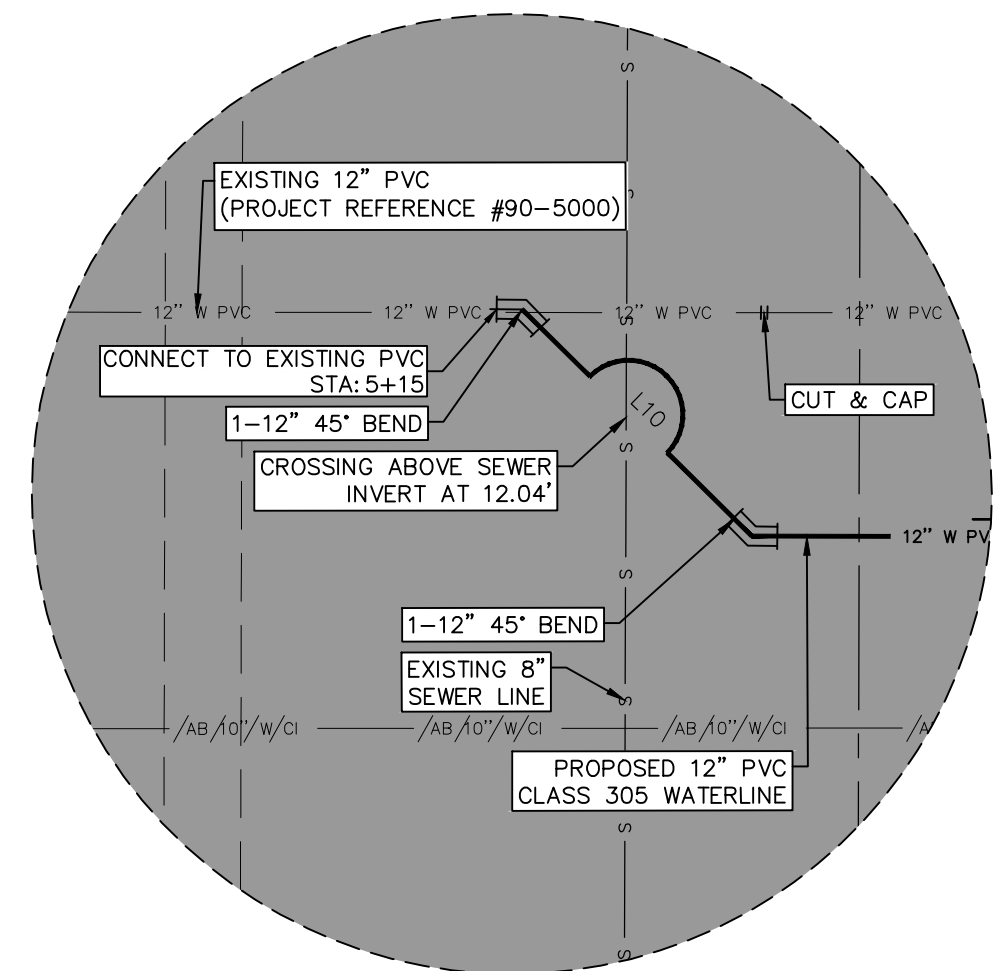
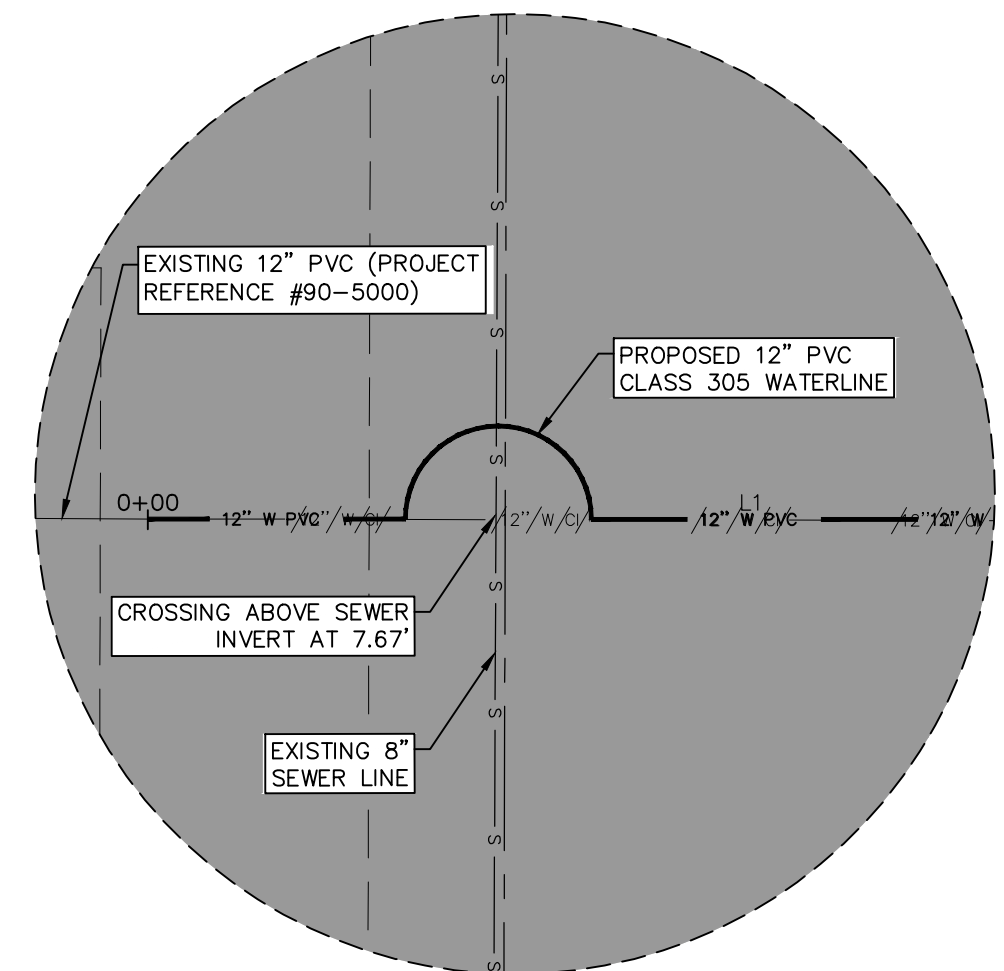
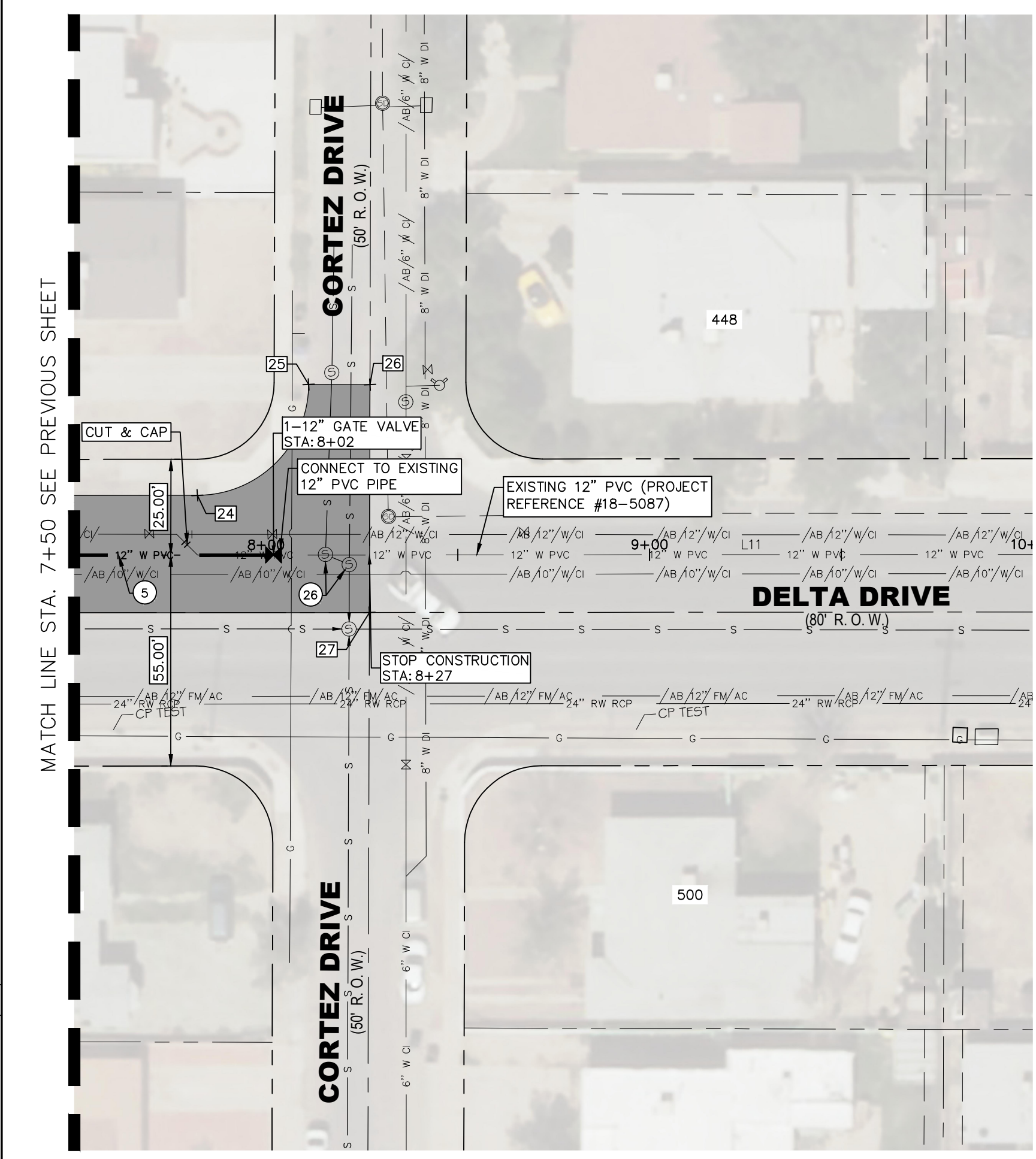

LEGEND:

---	SUBDIVISION LINE	[Pattern]	EXISTING CONCRETE
---	RIGHT-OF-WAY LINE	[Pattern]	PROPOSED CONCRETE
---	PROPERTY LINE	[Pattern]	PROPOSED 2" HMAc PAVEMENT
---	CENTER LINE	[Pattern]	EXISTING CURB & GUTTER
UE	EXISTING UNDERGROUND CABLE	[Pattern]	PROPOSED CURB & GUTTER
W	FORCE MAIN PIPE	[Symbol]	EXISTING WATER VALVE
S	EXISTING SANITARY SEWER LINE	[Symbol]	EXISTING SANITARY SEWER MANHOLE
W	PROPOSED WATER LINE	[Symbol]	EXISTING STORM SEWER MANHOLE
W	EXISTING ABANDONED WATER LINE	[Symbol]	EXISTING TELEPHONE MANHOLE
G	EXISTING GAS LINE	[Symbol]	EXISTING TELEPHONE BOX
W	PROPOSED WATER LINE TO BE ABANDONED	[Symbol]	EXISTING ELECTRIC/TRAFFIC SIGNAL BOX
RW	EXISTING RECLAIMED WATER LINE	[Symbol]	EXISTING PARKING/ROAD SIGN
[Symbol]	REPLACE SERVICE LINE FROM PROPOSED MAIN TO EXISTING METER	[Symbol]	EXISTING GAS VALVE
[Symbol]	REPLACE SERVICE LINE FROM PROPOSED MAIN TO EXISTING METER BY BORING METHOD	[Symbol]	PROPOSED GATE VALVE
[Symbol]	EXISTING SERVICE LINE TO REMAIN UNDISTURBED	[Symbol]	FOUND CHISELED "X" ON CONCRETE
[Symbol]	PROPOSED VERTICAL BENDS		
[Symbol]	EXISTING FIRE HYDRANT		
[Symbol]	PROPOSED FIRE HYDRANT		

STOP!
CALL BEFORE YOU DIG

BROCK & BUSTILLOS INC.
CONSULTING CIVIL ENGINEERS
LAND SURVEYORS

417 EXECUTIVE CENTER
EL PASO, TEXAS 79902
WWW.BROCKBUSTILLOS.COM

PH (915) 542-4900
FAX (915) 542-2867
TBPE Firm Reg. No.: F-737

B&B JOB No.: 05970-046

Notar Public
HECTOR MARTINEZ
132659
LICENSED PROFESSIONAL ENGINEER

el paso WATER

Designed:	H.M.	Material Size Clarification, Updated Quantities, Updated Dwg Texas 811	E.R.	04/07/2022
Drawn:	I.V., E.R.			
Checked:	H.M.			
Approved:	H.M.			
Date:	APRIL 2022			
No.	Revision Description	By	Date	

DELTA DRIVE WATERLINE REPLACEMENT

CONCEPCION ST TO CORTEZ DR
STA. 0+00 TO STA. 8+27

Job Number: 05970-046

Sheet Number: 4 OF 17

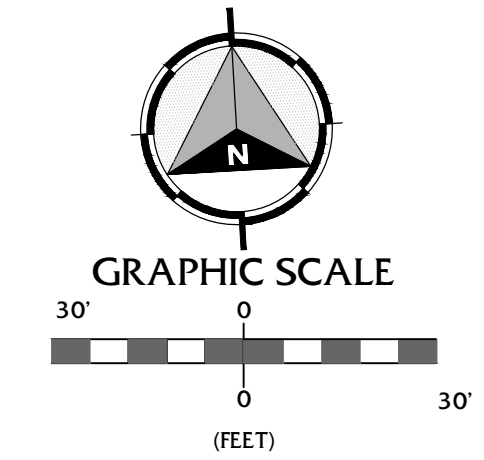
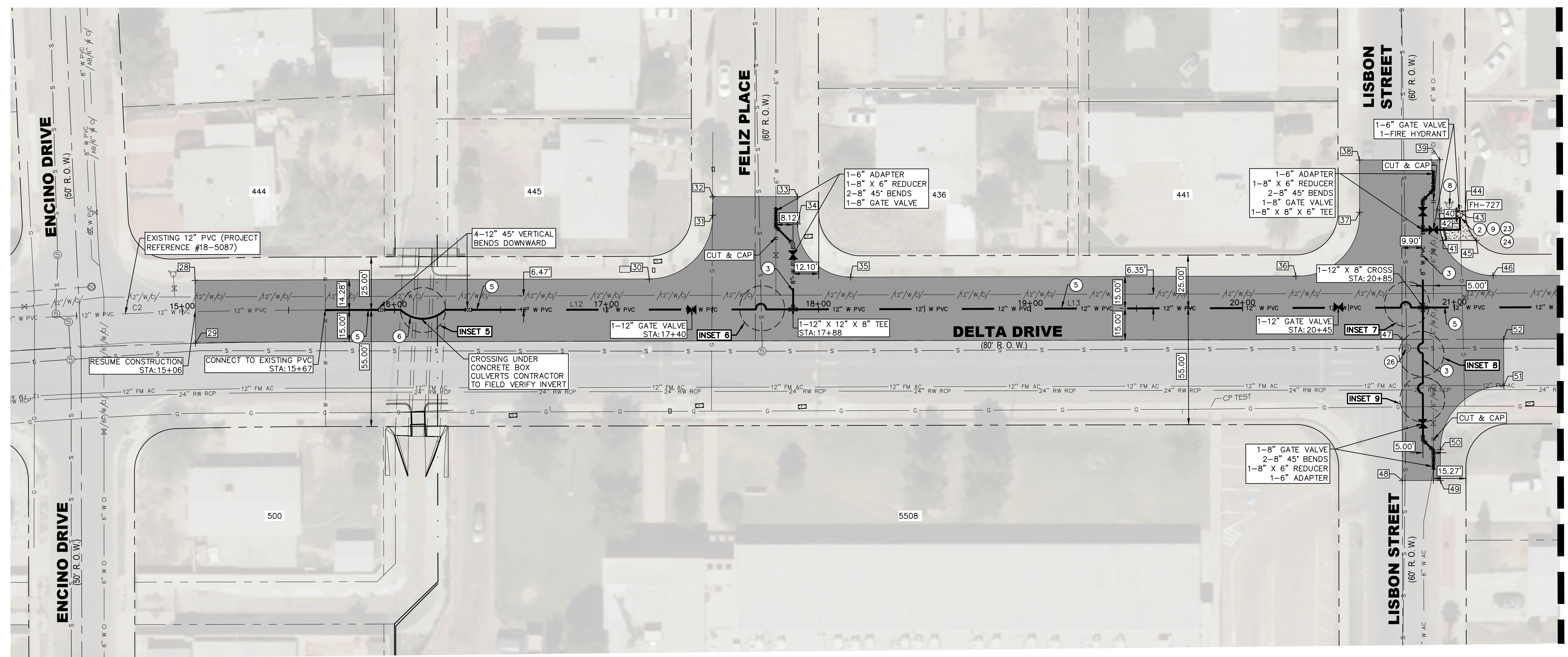

POINT TABLE			POINT TABLE		
POINT #	NORTHING	EASTING	POINT #	NORTHING	EASTING
28	10656260.1802	403636.8161	41	10656245.2506	404225.5434
29	10656230.4942	403635.2452	42	10656255.2194	404232.6255
30	10656248.4926	403850.7140	43	10656258.7336	404232.8270
31	10656276.7932	403882.3636	44	10656258.5003	404236.8942
32	10656285.5807	403882.8481	45	10656244.3484	404241.2733
33	10656283.2770	403922.7819	46	10656227.3372	404248.1686
34	10656270.3646	403922.0511	47	10656199.7209	404203.6078
35	10656243.9899	403945.6349	48	10656133.2389	404199.9423
36	10656232.4280	404155.3352	49	10656132.2654	404217.9160
37	10656260.7237	404187.0730	50	10656146.8213	404218.7094
38	10656285.3743	404188.4321	51	10656175.1440	404250.2974
39	10656283.2896	404226.2428	52	10656197.1114	404251.4944
40	10656255.6690	404224.6796			

NEW CONSTRUCTION SUMMARY DELTA DRIVE FROM STA. 7+50 TO 21+50				
NO.	ITEM	STATION	ASBUILT	QUANTITY
1	6" PVC (CLASS 305) WATERLINE			24 LF
2	8" PVC (CLASS 305) WATERLINE			197 LF
5	12" PVC (CLASS 305) WATERLINE			539 LF
6	12" DI (CLASS 350) WATERLINE			45 LF
7	TRENCH SAFETY SYSTEM			805 LF
8	REMOVE & SALVAGE FIRE HYDRANTS			1 EA
9	NEW FIRE HYDRANTS			1 EA
16	4-SACK SOIL CEMENT BACKFILL & SUBGRADE			537 SY
20	2" HMAc PAVEMENT REPLACEMENT (BRIDGE)			537 SY
21	2" MILL AND OVERLAY EXISTING HMAc BEYOND BRIDGE			2290 SY
23	REMOVE & REPLACE CONCRETE SIDEWALK			128 SF
24	REMOVE & REPLACE CURB & GUTTER			10 LF
26	CONCRETE APRON FOR PAVEMENT PENETRATIONS			1 EA

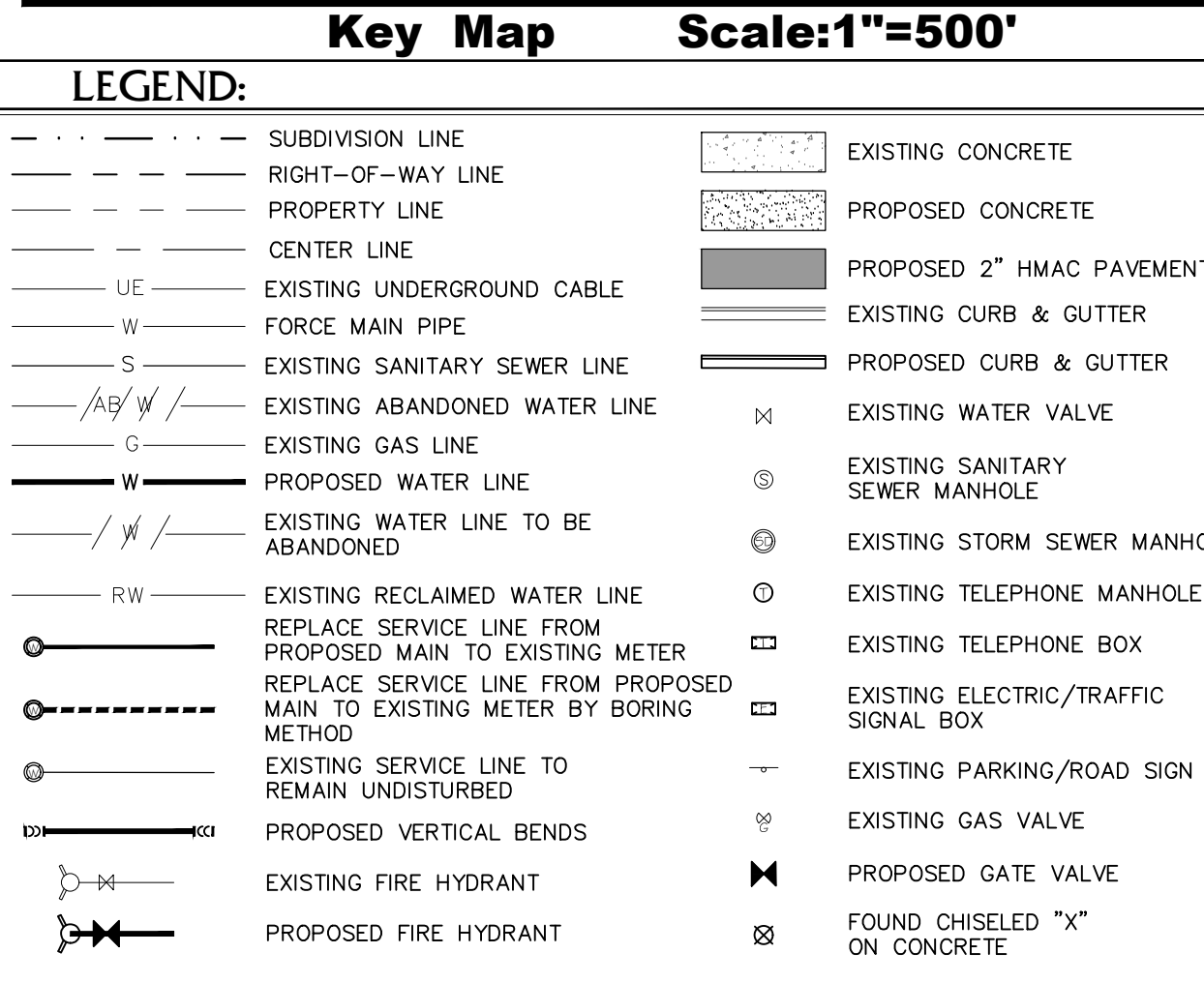
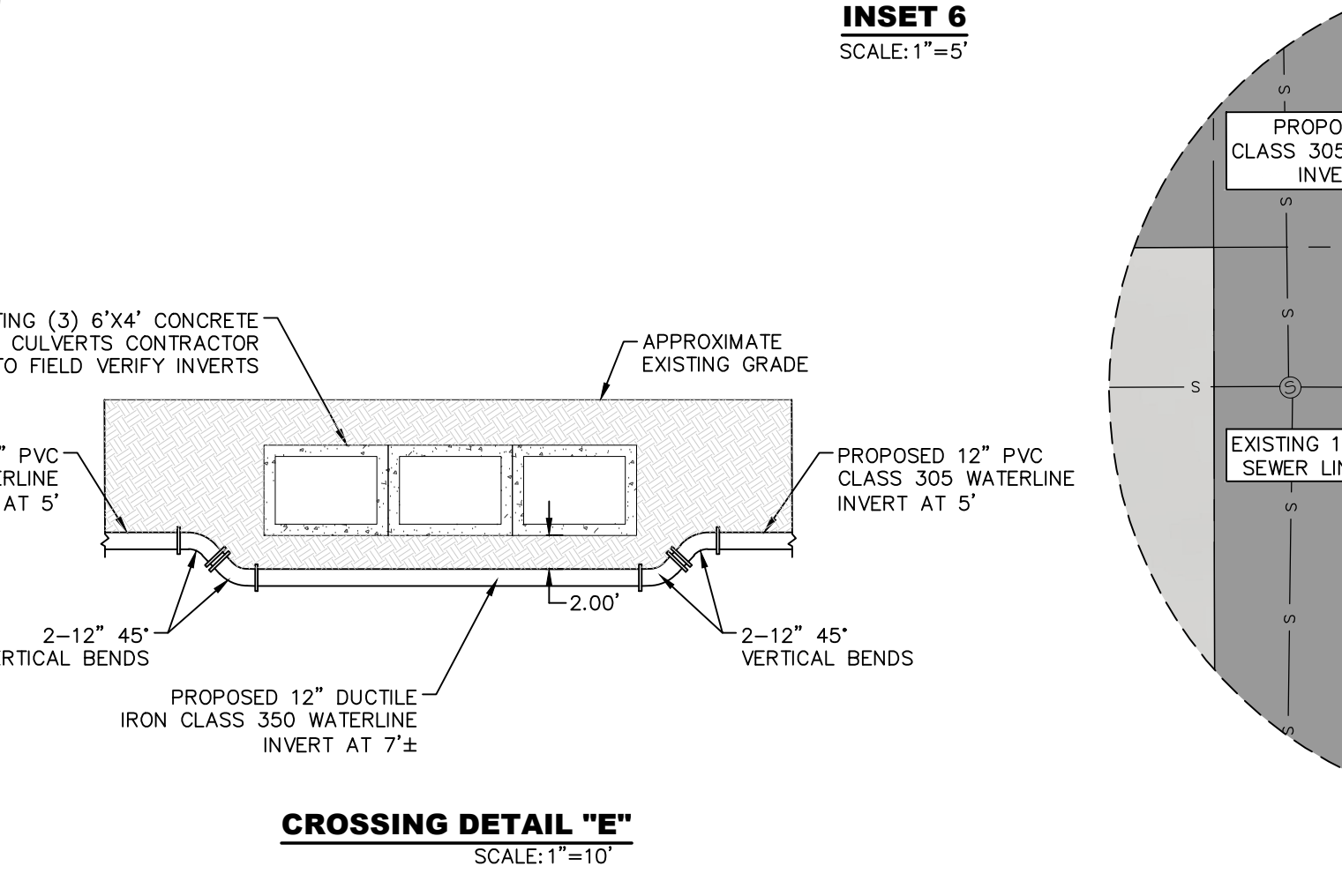
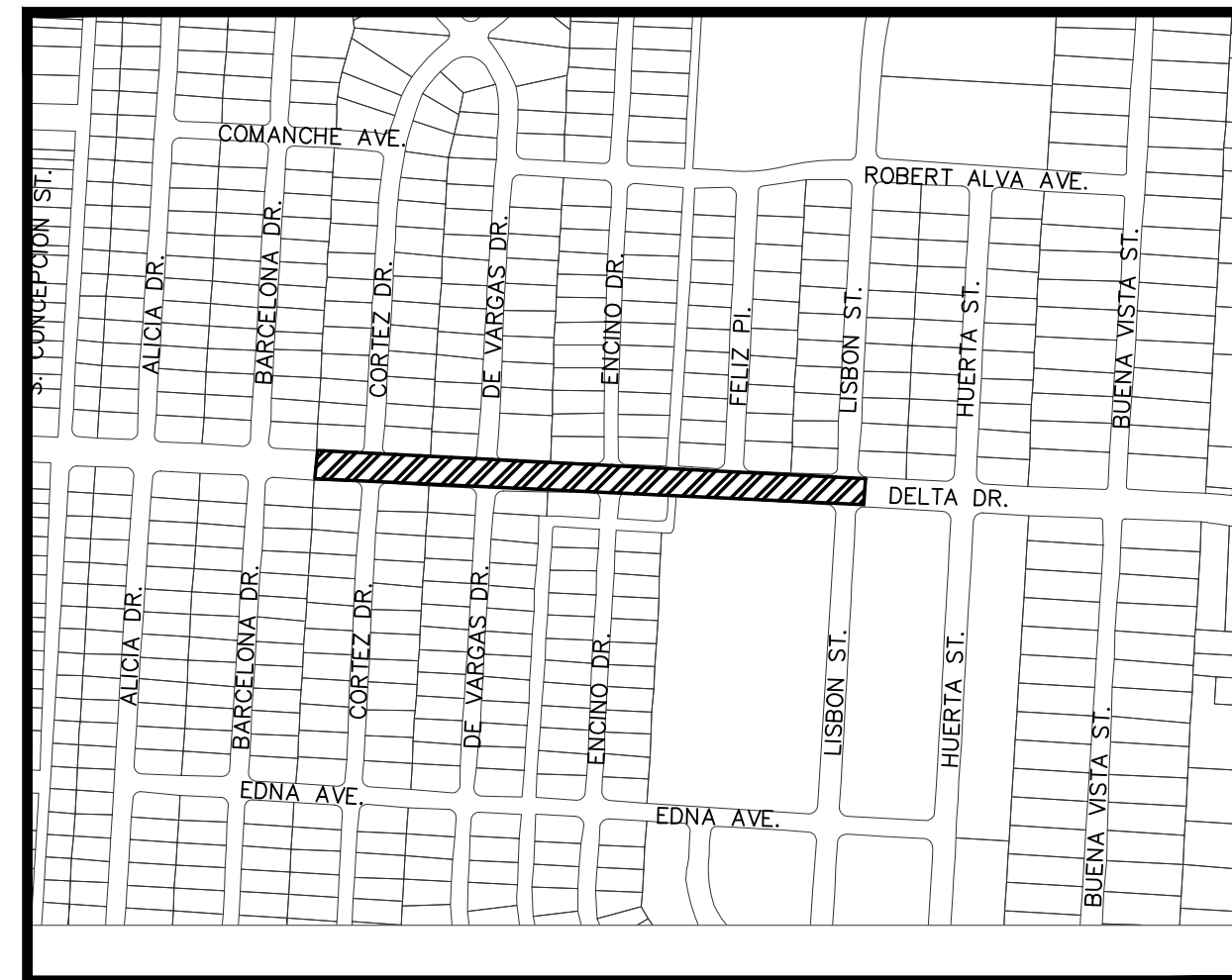
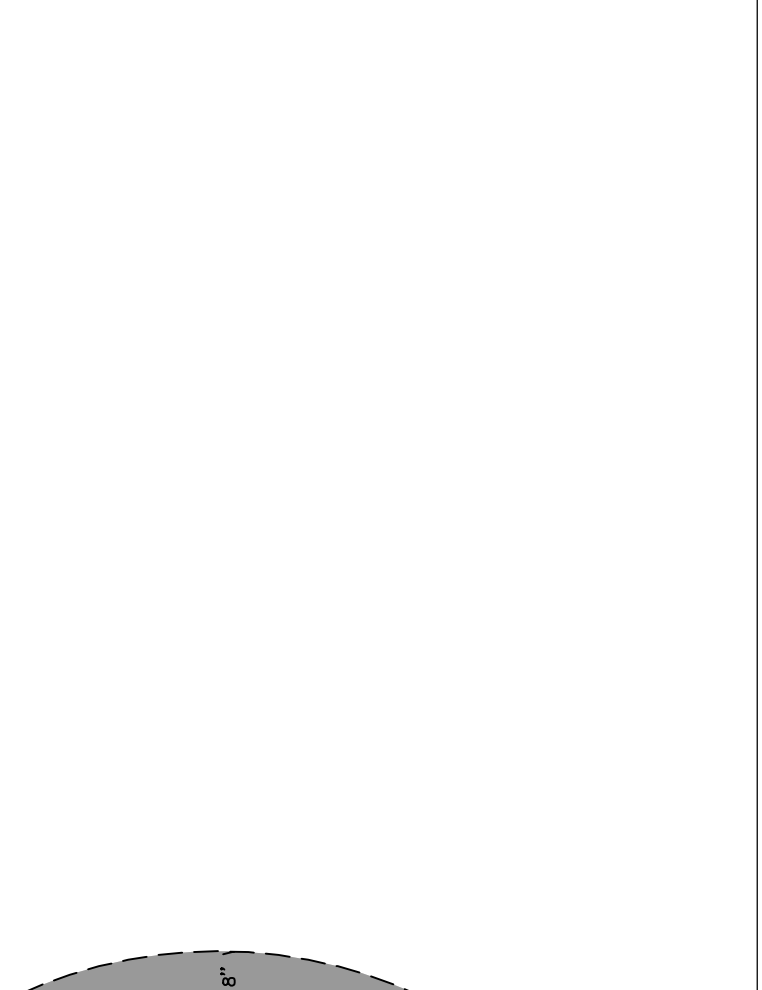
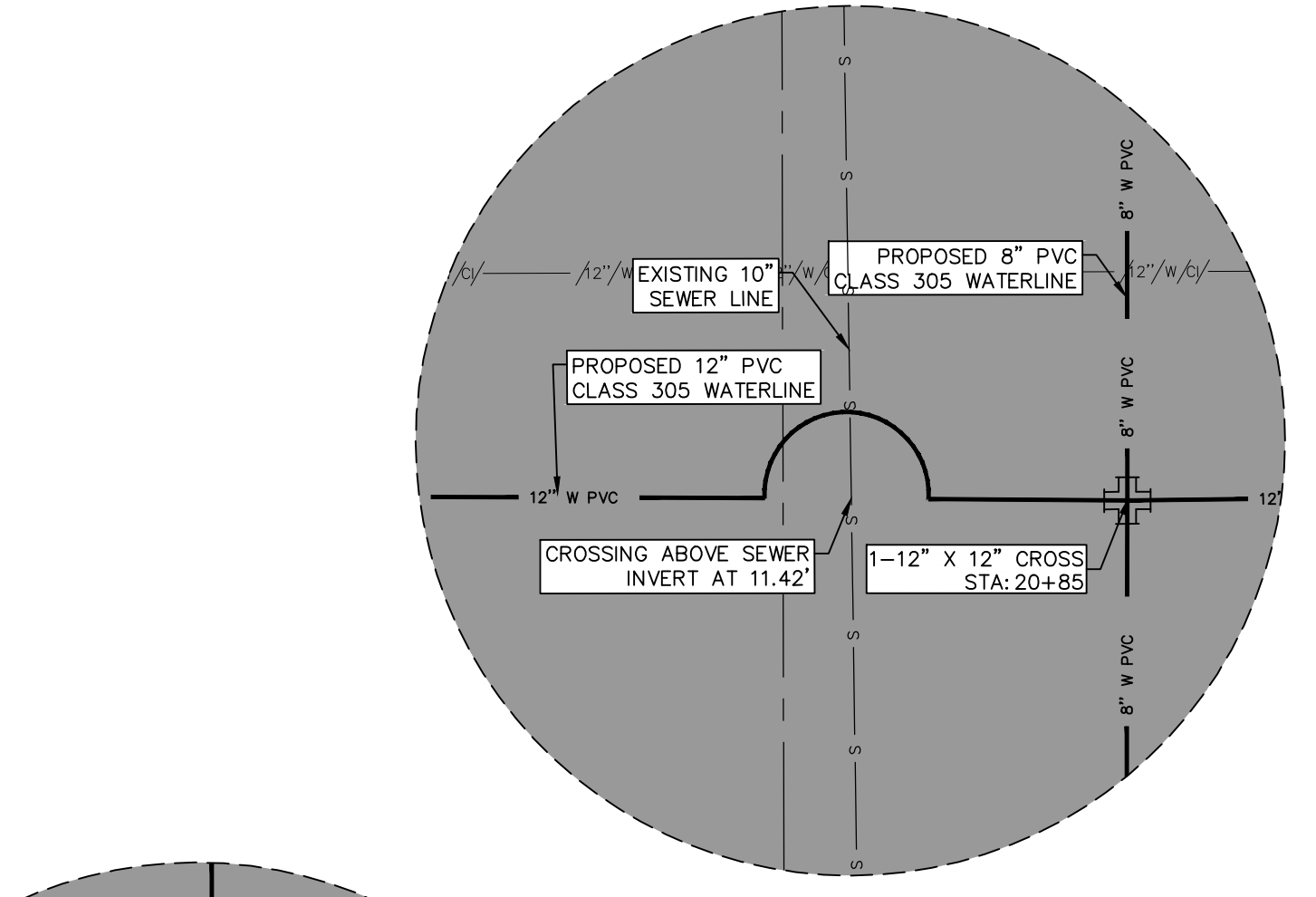
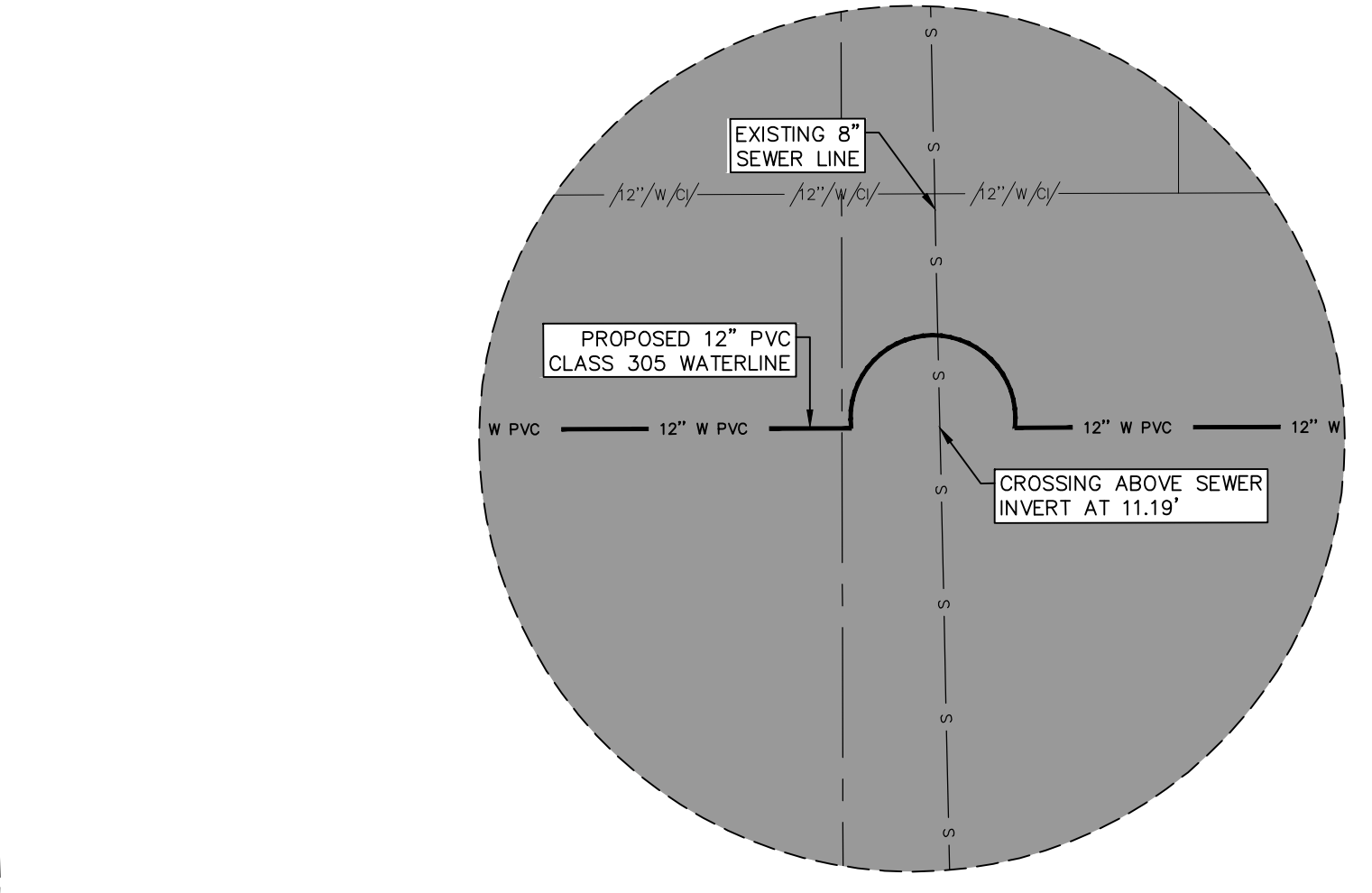
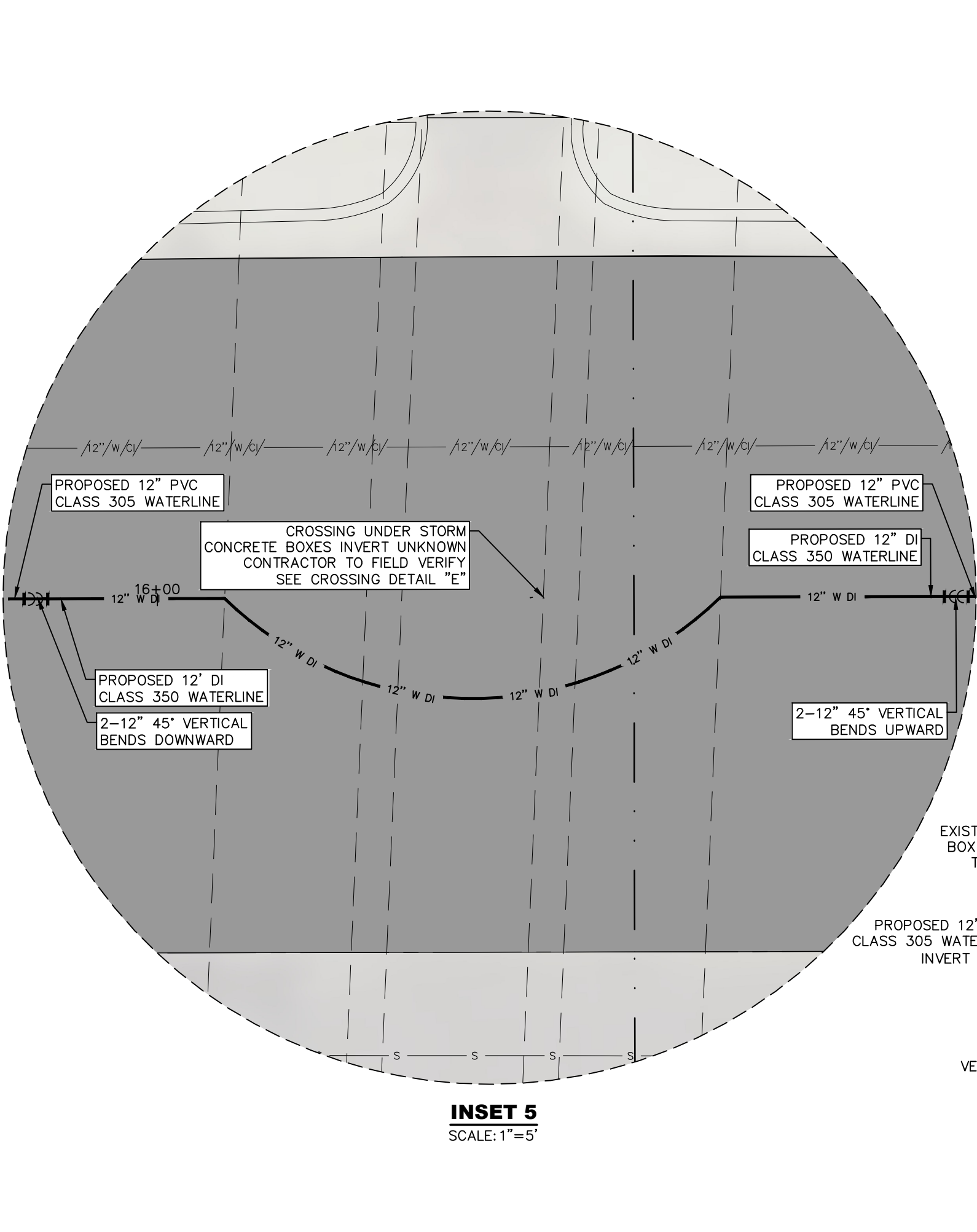

LEGEND:

---	SUBDIVISION LINE	[Pattern]	EXISTING CONCRETE
- - -	RIGHT-OF-WAY LINE	[Pattern]	PROPOSED CONCRETE
---	PROPERTY LINE	[Pattern]	PROPOSED 2" HMAc PAVEMENT
---	CENTER LINE	[Pattern]	EXISTING CURB & GUTTER
UE	EXISTING UNDERGROUND CABLE	[Pattern]	PROPOSED CURB & GUTTER
W	FORCE MAIN PIPE	[Symbol]	EXISTING WATER VALVE
S	EXISTING SANITARY SEWER LINE	[Symbol]	EXISTING SANITARY SEWER MANHOLE
W	PROPOSED WATER LINE	[Symbol]	EXISTING STORM SEWER MANHOLE
W	EXISTING ABANDONED WATER LINE	[Symbol]	EXISTING TELEPHONE MANHOLE
W	EXISTING RECLAIMED WATER LINE	[Symbol]	EXISTING TELEPHONE BOX
W	REPLACE SERVICE LINE FROM PROPOSED MAIN TO EXISTING METER	[Symbol]	EXISTING ELECTRIC/TRAFFIC SIGNAL BOX
W	REPLACE SERVICE LINE FROM PROPOSED MAIN TO EXISTING METER BY BORING METHOD	[Symbol]	EXISTING PARKING/ROAD SIGN
W	EXISTING SERVICE LINE TO REMAIN UNDISTURBED	[Symbol]	EXISTING GAS VALVE
W	PROPOSED VERTICAL BENDS	[Symbol]	PROPOSED GATE VALVE
W	EXISTING FIRE HYDRANT	[Symbol]	FOUND CHISELED "X" ON CONCRETE
W	PROPOSED FIRE HYDRANT		

STOP!
CALL BEFORE YOU DIG

BROCK & BUSTILLOS INC.
CONSULTING CIVIL ENGINEERS
LAND SURVEYORS

417 EXECUTIVE CENTER
EL PASO, TEXAS 79902
WWW.BROCKBUSTILLOS.COM

PH (915) 542-4900
FAX (915) 542-2867
TBPB Firm Reg. No.: F-737

B&B JOB No.: 05970-046

HECTOR MARTINEZ
LICENSED PROFESSIONAL ENGINEER
132659

04/11/2022

el paso WATER

Designed:	H.M.	Material Size Clarification, Updated Quantities, Updated Dig Texas 811	E.R.	04/07/2022
Drawn:	I.V., E.R.			
Checked:	H.M.			
Approved:	H.M.			
Date:	APRIL 2022			
No.	Revision Description	By	Date	

DELTA DRIVE WATERLINE REPLACEMENT

**ENCINO DR TO LISBON ST
STA. 15+06 TO STA. 21+50**

Job Number: 05970-046

Sheet Number: 5 OF 17

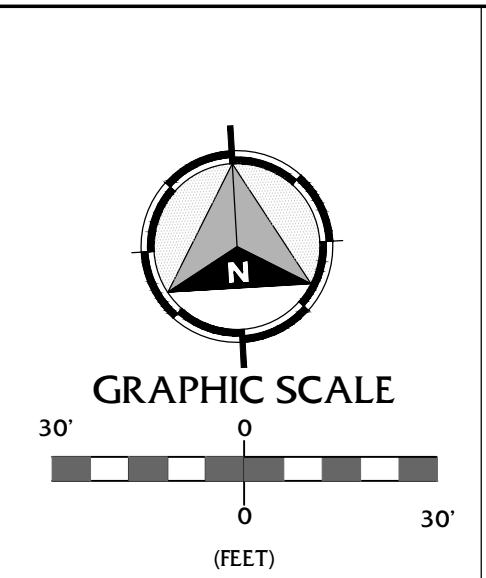
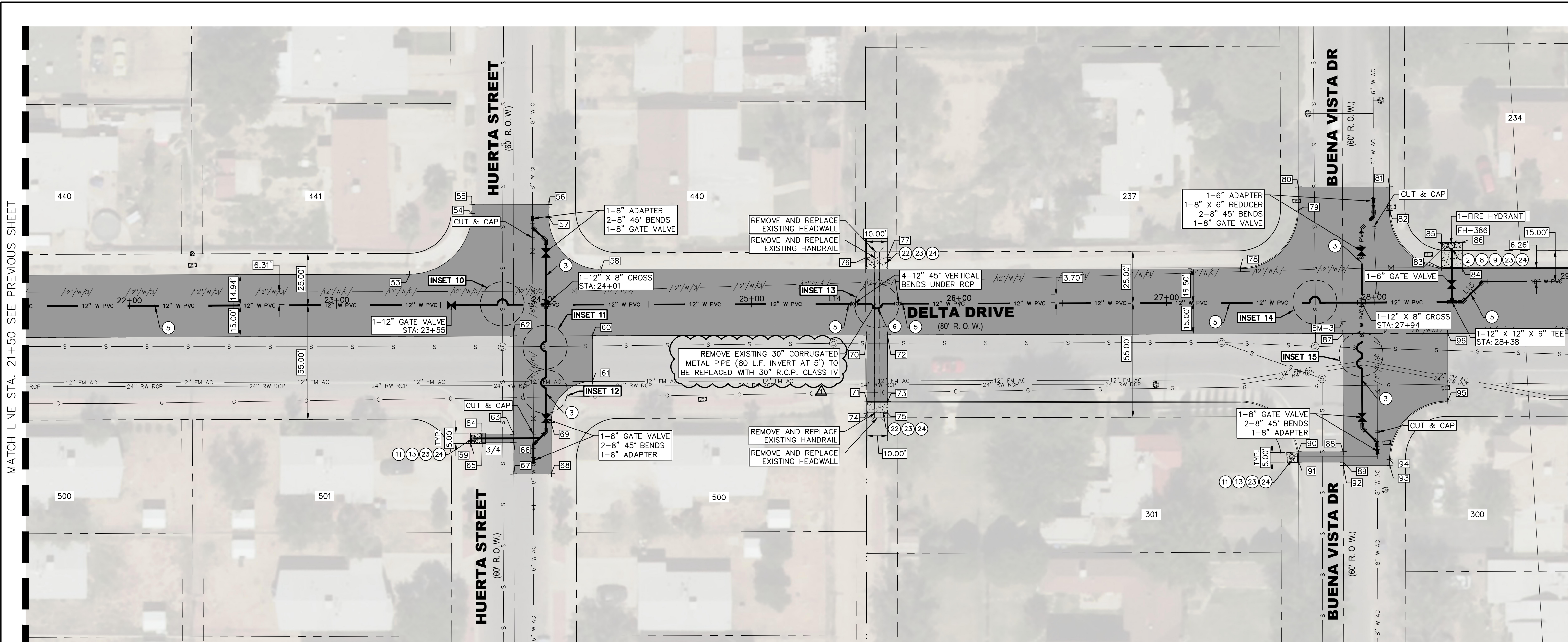

MATCH LINE STA. 29+00 SEE NEXT SHEET

MATCH LINE STA. 21+50 SEE PREVIOUS SHEET

POINT TABLE			POINT TABLE		
POINT #	NORTHING	EASTING	POINT #	NORTHING	EASTING
53	10656215.4372	404464.8759	76	10656210.7709	404685.2219
54	10656242.8114	404496.4096	77	10656210.2264	404695.2071
55	10656247.1548	404496.6636	78	10656195.1791	404864.7679
56	10656245.0531	404533.7990	79	10656221.8557	404894.3170
57	10656238.9565	404533.4540	80	10656232.9321	404894.9623
58	10656212.5838	404557.0015	81	10656230.4549	404938.8505
59	10656132.2036	404489.4691	82	10656219.1299	404938.1910
60	10656180.7848	404551.1014	83	10656189.9424	404961.6110
61	10656158.8174	404549.9041	84	10656189.1311	404971.5656
62	10656182.8530	404513.1487	85	10656202.2965	404962.3042
63	10656135.5319	404510.5396	86	10656201.7239	404972.2878
64	10656136.8896	404495.2415	87	10656161.0815	404912.4265
65	10656131.8975	404494.9604	88	10656104.2176	404909.2481
66	10656131.5379	404510.3194	89	10656099.2254	404908.9691
67	10656116.4012	404509.4848	90	10656105.4222	404887.5385
68	10656115.4277	404527.4585	91	10656100.4145	404887.5378
69	10656139.9771	404528.8478	92	10656097.5632	404908.9241
70	10656173.5826	404683.1784	93	10656096.2936	404931.3341
71	10656141.3963	404681.4232	94	10656099.3012	404931.4568
72	10656173.0381	404693.1636	95	10656125.6715	404961.0137
73	10656140.8371	404691.4076	96	10656158.2731	404962.8773
74	10656135.9050	404681.1150	BM-3	10656166.7600	404912.3300
75	10656135.3461	404691.0927			

NEW CONSTRUCTION SUMMARY DELTA DRIVE FROM STA. 21+50 TO 29+00				
NO.	ITEM	STATION	ASBUILT	QUANTITY
2	6" PVC (CLASS 305) WATERLINE			26 LF
3	8" PVC (CLASS 305) WATERLINE			255 LF
5	12" PVC (CLASS 305) WATERLINE			727 LF
6	12" DI (CLASS 350) WATERLINE			24 LF
7	TRENCH SAFETY SYSTEM			1032 LF
8	REMOVE & SALVAGE FIRE HYDRANTS			EA
9	NEW FIRE HYDRANTS			1 EA
10	FURNISH AND INSTALL METER BOX AND LID			1 EA
11	3/4" COPPER SERVICE CONNECTIONS			2 EA
13	3/4" COPPER SERVICE LINE			71 LF
16	4-SACK SOIL CEMENT BACKFILL & SUBGRADE			688 SY
17	REMOVE CMP AND REPLACE WITH 30" RCP CLASS IV			80 SY
20	2" HMAC PAVEMENT REPLACEMENT (BRIDGE)			688 SY
21	2" MILL AND OVERLAY EXISTING HMAC BEYOND BRIDGE			2769 SY
22	REMOVE & REPLACE HANDRAIL			20 LF
23	REMOVE & REPLACE CONCRETE SIDEWALK			262 SF
24	REMOVE & REPLACE CURB & GUTTER			40 LF

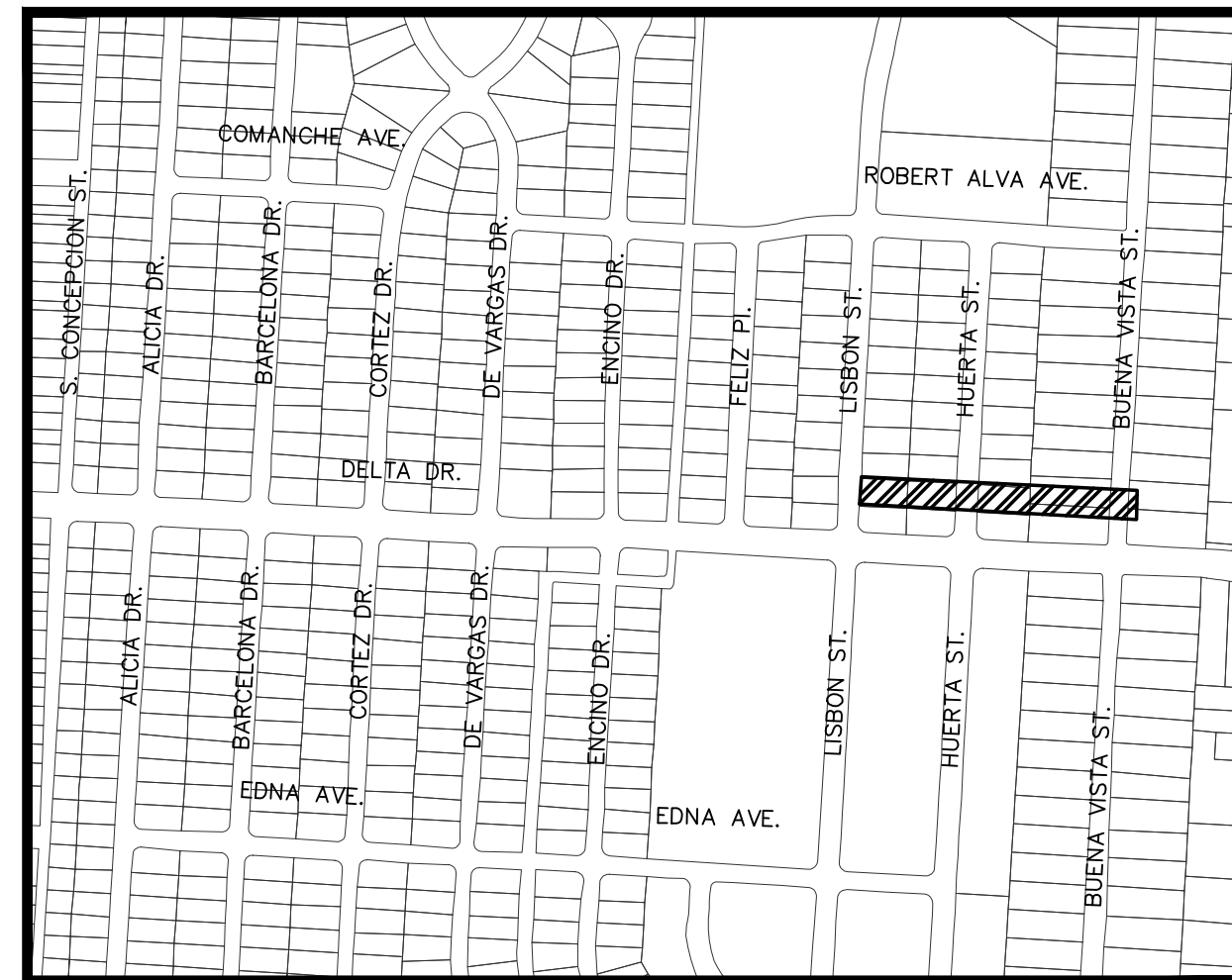

Key Map Scale: 1"=500'

LEGEND:

---	SUBDIVISION LINE	[Pattern]	EXISTING CONCRETE
- - - -	RIGHT-OF-WAY LINE	[Pattern]	PROPOSED CONCRETE
---	PROPERTY LINE	[Pattern]	PROPOSED 2" HMAC PAVEMENT
---	CENTER LINE	[Pattern]	EXISTING CURB & GUTTER
UE	EXISTING UNDERGROUND CABLE	[Pattern]	PROPOSED CURB & GUTTER
W	FORCE MAIN PIPE	[Symbol]	EXISTING WATER VALVE
S	EXISTING SANITARY SEWER LINE	[Symbol]	EXISTING SANITARY SEWER MANHOLE
AB	EXISTING ABANDONED WATER LINE	[Symbol]	EXISTING STORM SEWER MANHOLE
G	EXISTING GAS LINE	[Symbol]	EXISTING TELEPHONE MANHOLE
W	PROPOSED WATER LINE	[Symbol]	EXISTING TELEPHONE BOX
W	EXISTING WATER LINE TO BE ABANDONED	[Symbol]	EXISTING ELECTRIC/TRAFFIC SIGNAL BOX
RW	EXISTING RECLAIMED WATER LINE	[Symbol]	EXISTING PARKING/ROAD SIGN
[Symbol]	REPLACE SERVICE LINE FROM PROPOSED MAIN TO EXISTING METER	[Symbol]	EXISTING GAS VALVE
[Symbol]	REPLACE SERVICE LINE FROM PROPOSED MAIN TO EXISTING METER BY BORING METHOD	[Symbol]	PROPOSED GATE VALVE
[Symbol]	EXISTING SERVICE LINE TO REMAIN UNDISTURBED	[Symbol]	EXISTING FIRE HYDRANT
[Symbol]	PROPOSED VERTICAL BENDS	[Symbol]	PROPOSED FIRE HYDRANT
[Symbol]	EXISTING FIRE HYDRANT	[Symbol]	FOUND CHISELED "X" ON CONCRETE

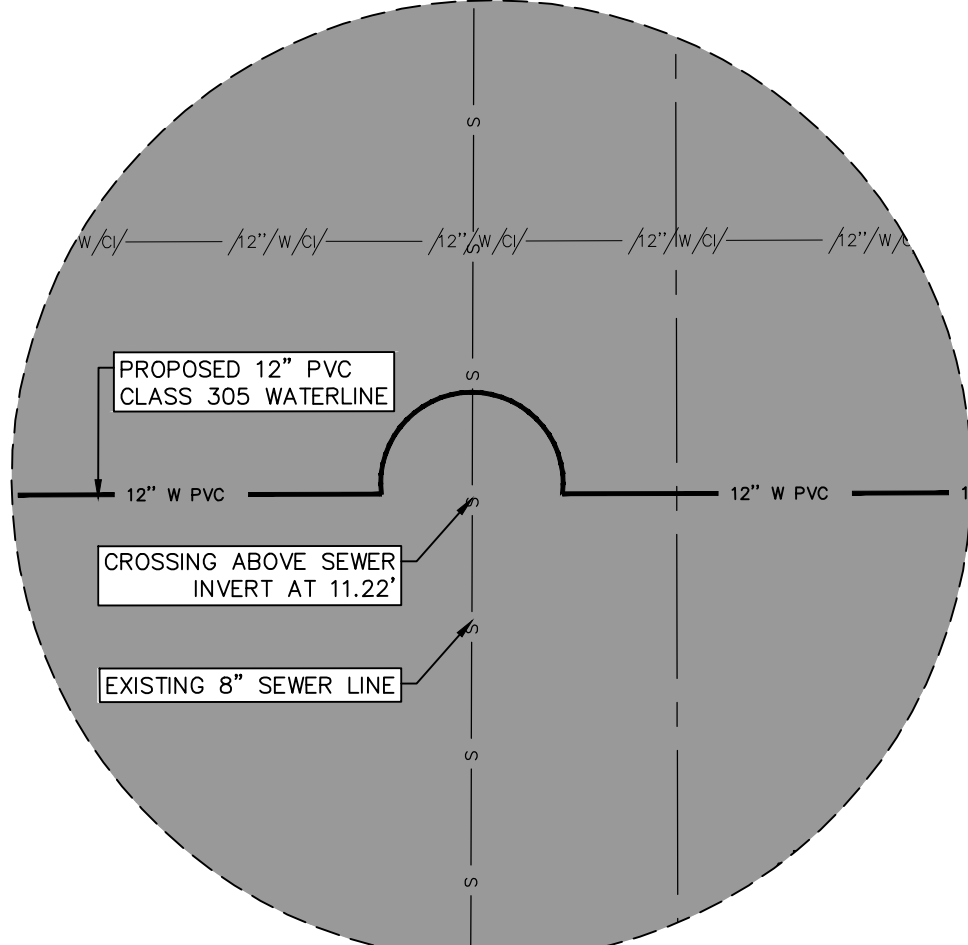

INSET 10 SCALE: 1"=5'

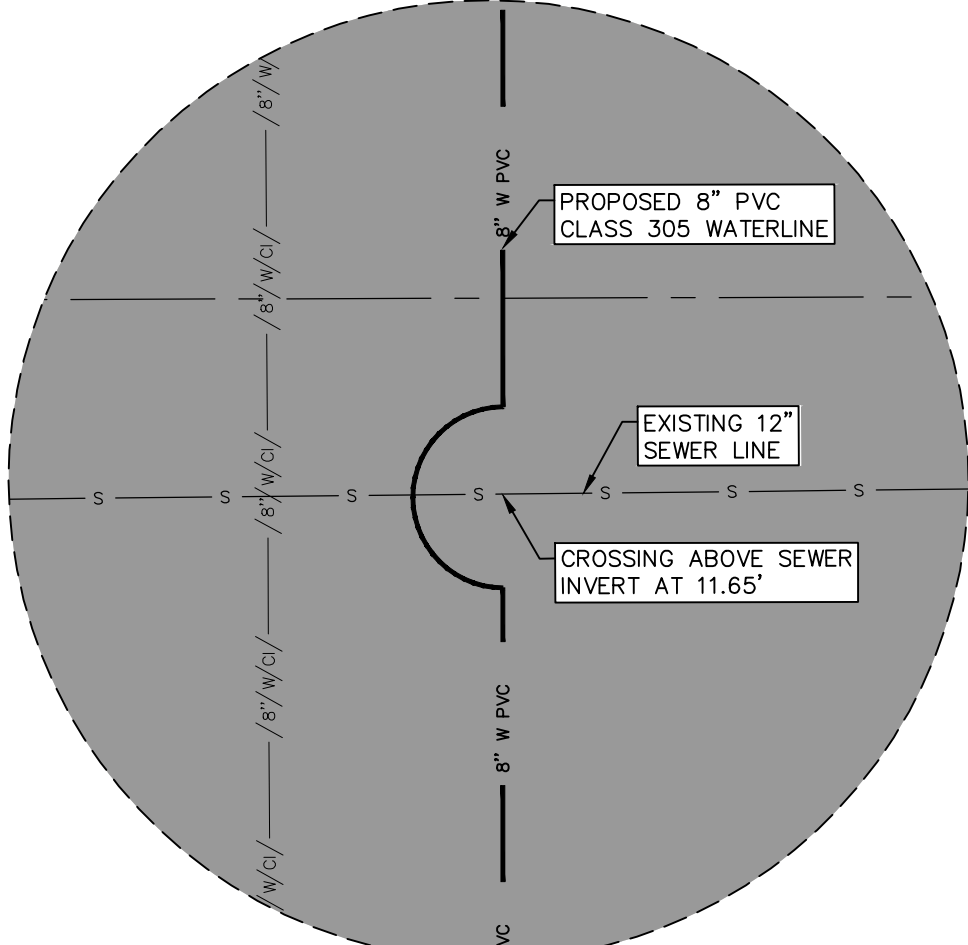

INSET 11 SCALE: 1"=5'

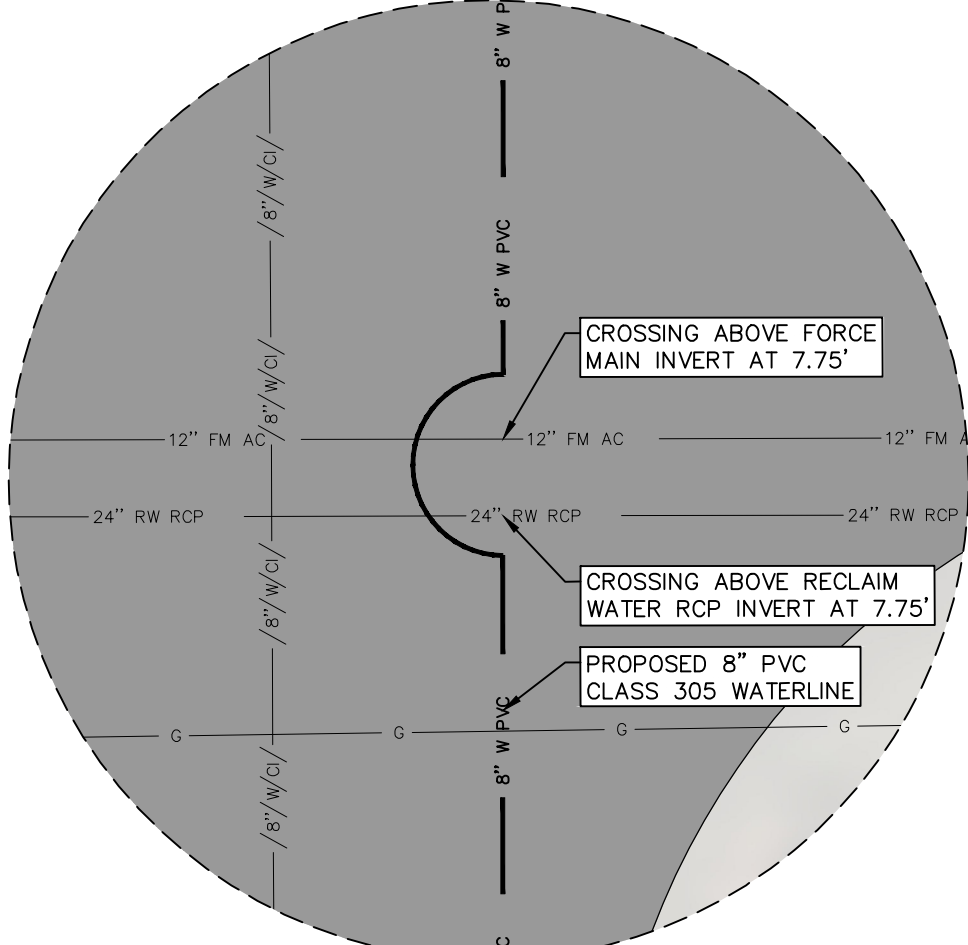

INSET 12 SCALE: 1"=5'

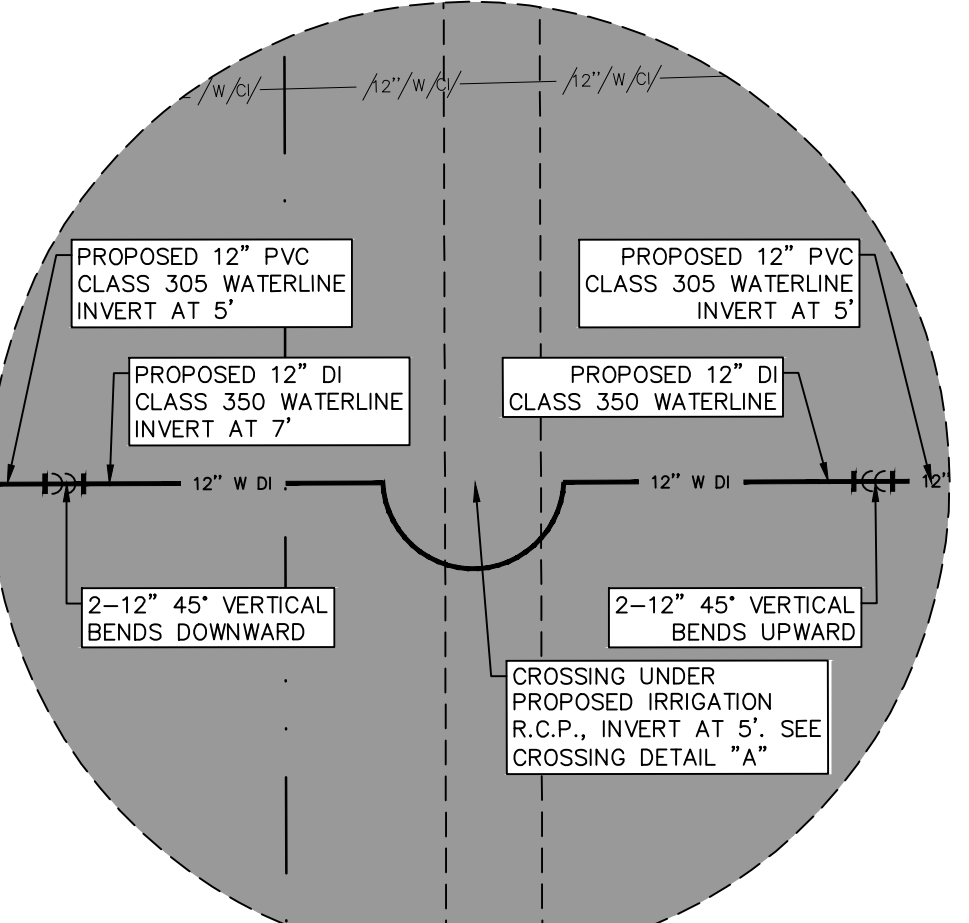

INSET 13 SCALE: 1"=5'

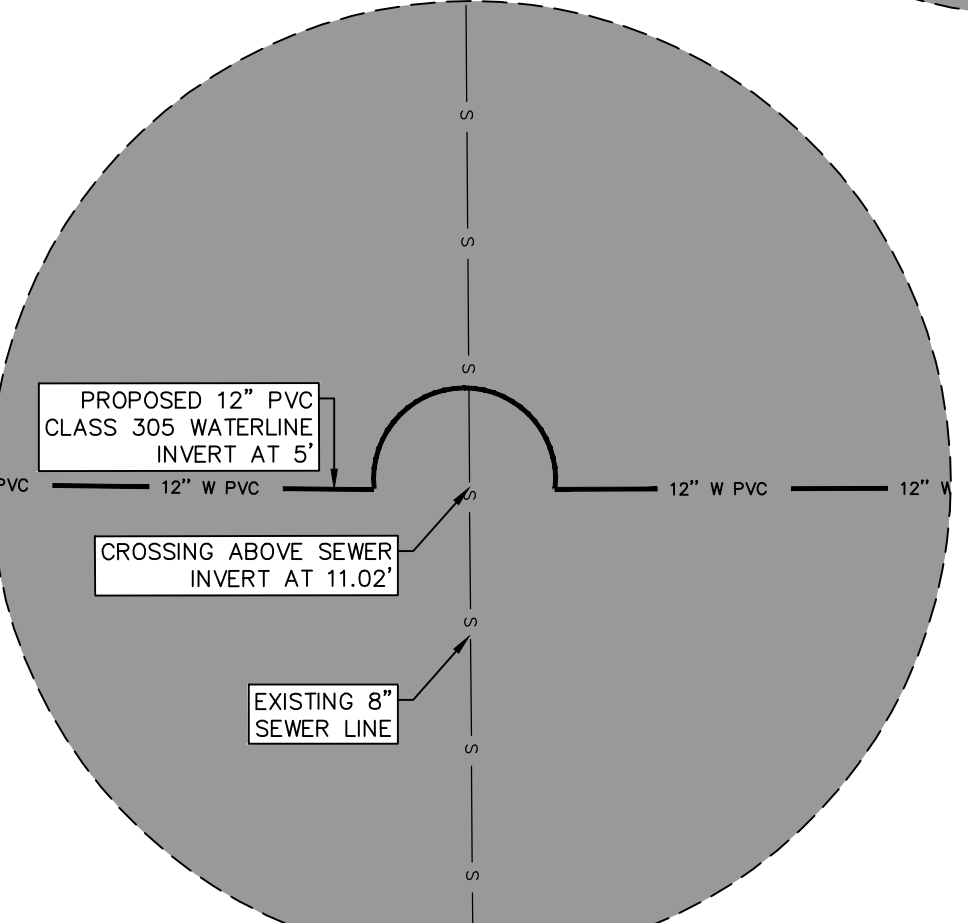

INSET 14 SCALE: 1"=5'

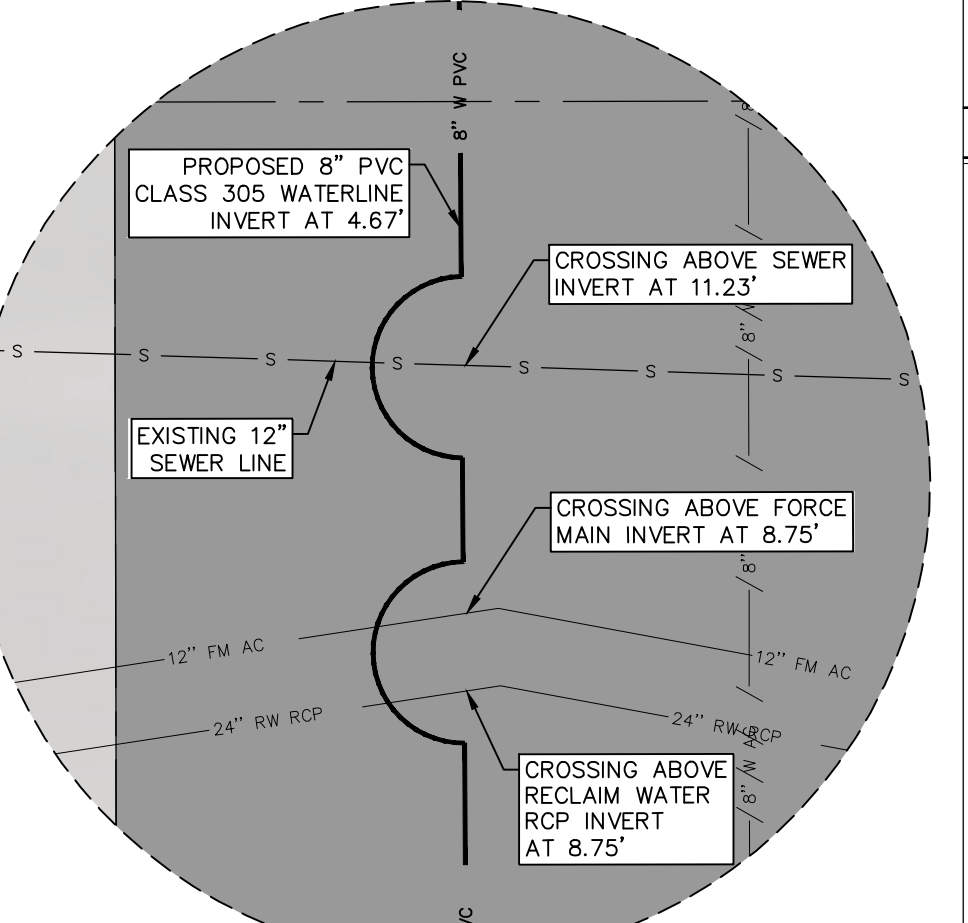

INSET 15 SCALE: 1"=5'

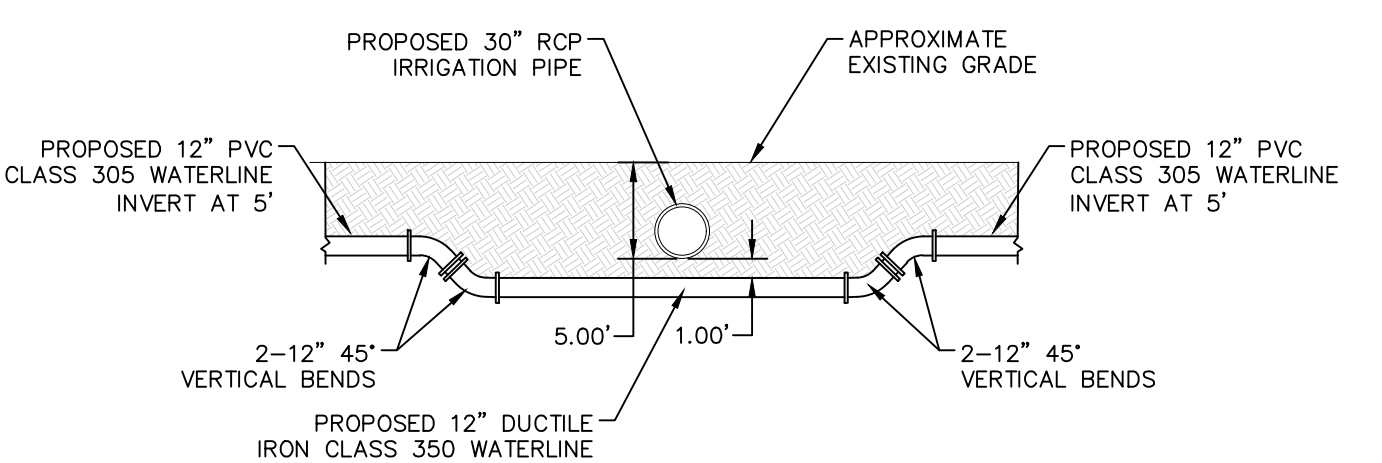

CROSSING DETAIL "A" SCALE: 1"=10'

STOP! CALL BEFORE YOU DIG

BROCK & BUSTILLOS INC.
CONSULTING CIVIL ENGINEERS
LAND SURVEYORS

417 EXECUTIVE CENTER
EL PASO, TEXAS 79902
WWW.BROCK&BUSTILLOS.COM

PH (915) 542-4900
FAX (915) 542-2867
TBPE Firm Reg. No.: F-737

B&B JOB No.: 05970-046

Hector Martinez

HECTOR MARTINEZ
LICENSED PROFESSIONAL ENGINEER
132659

04/11/2022

el paso WATER

Designed:	H.M.	Material Size Clarification, Updated Quantities, Updated Dig Texas 811	E.R.	04/07/2022
Drawn:	I.V., E.R.			
Checked:	H.M.			
Approved:	H.M.			
Date:	APRIL 2022			
No.	Revision Description	By	Date	

DELTA DRIVE WATERLINE REPLACEMENT

HUERTA ST TO BUENA VISTA DR FROM STA. 21+50 TO STA. 29+00

Job Number: 05970-046

Sheet Number: 6 OF 17

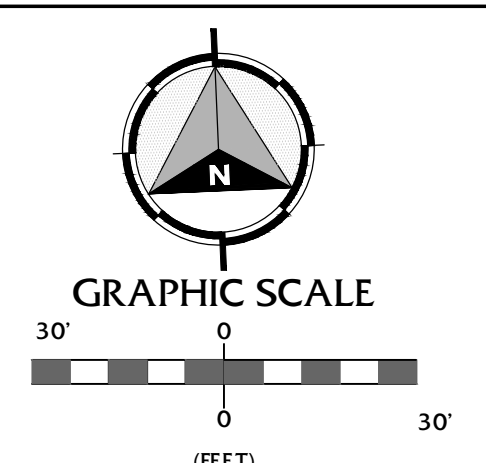
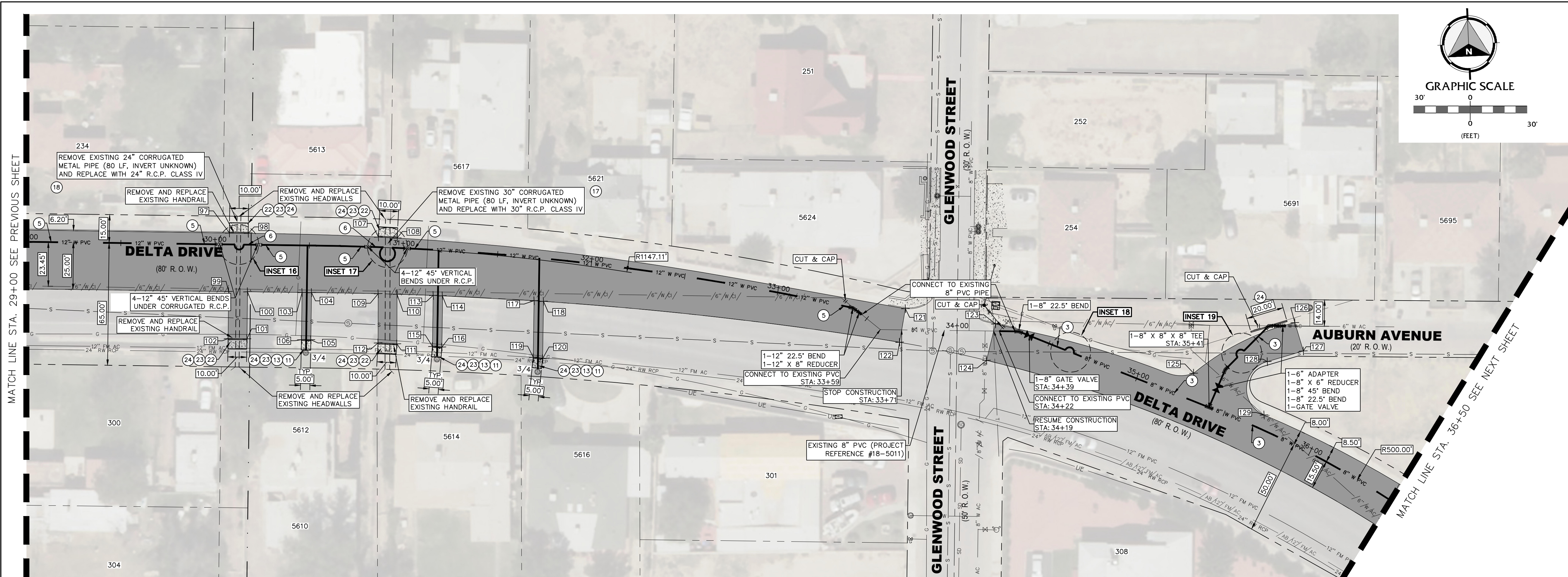

POINT TABLE			POINT TABLE		
POINT #	NORTHING	EASTING	POINT #	NORTHING	EASTING
97	10656179.9495	405132.1544	113	10656142.2639	405238.7739
98	10656179.3786	405142.1381	114	10656141.8629	405243.6109
99	10656148.9628	405130.4588	115	10656115.2674	405237.2301
100	10656148.3888	405140.4424	116	10656114.8541	405242.1924
101	10656123.4281	405139.0856	117	10656137.1947	405292.0890
102	10656124.0001	405129.1020	118	10656136.6611	405297.0667
103	10656146.8015	405169.3602	119	10656107.2302	405290.4195
104	10656146.5056	405174.3514	120	10656106.2856	405295.3363
105	10656121.4946	405172.9212	121	10656124.6331	405488.6994
106	10656121.7801	405167.9293	122	10656106.9478	405484.8747
107	10656174.4775	405211.0174	123	10656114.4843	405536.0704
108	10656173.4942	405220.9718	124	10656095.3842	405530.5439
109	10656144.4345	405209.6470	125	10656083.8854	405640.0219
110	10656143.7379	405219.6257	126	10656108.4429	405694.7849
111	10656117.3778	405218.4291	127	10656091.2466	405698.6250
112	10656118.3387	405208.4624	129	10656060.1803	405676.3704

NEW CONSTRUCTION SUMMARY DELTA DRIVE FROM STA. 36+50 TO 42+00				
NO.	ITEM	STATION	ASBUILT	QUANTITY
3	8" PVC (CLASS 305) WATERLINE			282 LF
5	12" PVC (CLASS 305) WATERLINE			412 LF
6	12" DI (CLASS 350) WATERLINE			45 LF
7	TRENCH SAFETY SYSTEM			743 LF
10	FURNISH AND INSTALL METER BOX AND LID			1 EA
11	3/4" COPPER SERVICE CONNECTIONS			3 EA
13	1/4" COPPER SERVICE LINE			171 LF
16	4-SACK SOIL CEMENT BACKFILL & SUBGRADE			496 SY
17	REMOVE CMP AND REPLACE WITH 30" RCP			80 LF
18	REMOVE CMP AND REPLACE WITH 24" RCP			80 LF
19	CONCRETE HEADWALL FOR RCP			4 EA
20	2" HMAc PAVEMENT REPLACEMENT (BRIDGE)			496 SY
21	2" MILL AND OVERLAY EXISTING HMAc BEYOND BRIDGE			1668 SY
22	REMOVE & REPLACE HANDRAIL			40 LF
23	REMOVE & REPLACE CONCRETE SIDEWALK			255 SF
24	REMOVE & REPLACE CURB & GUTTER			75 LF

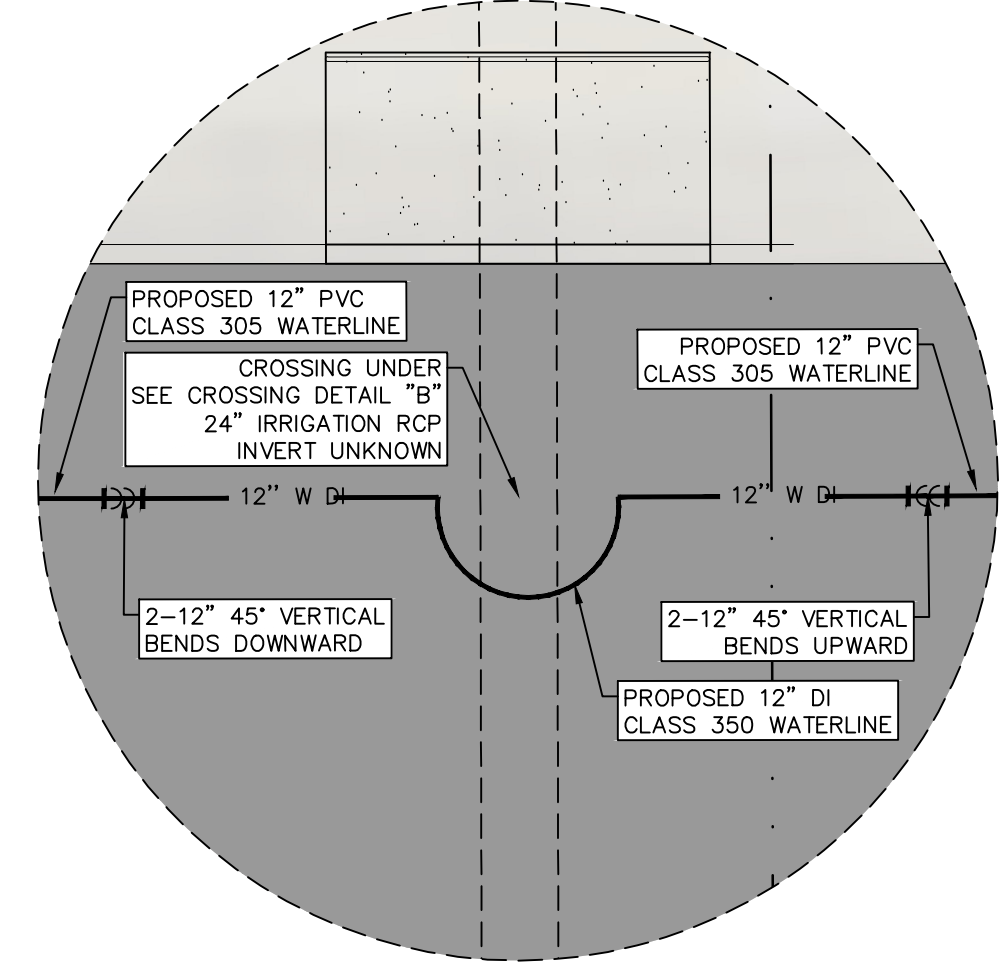
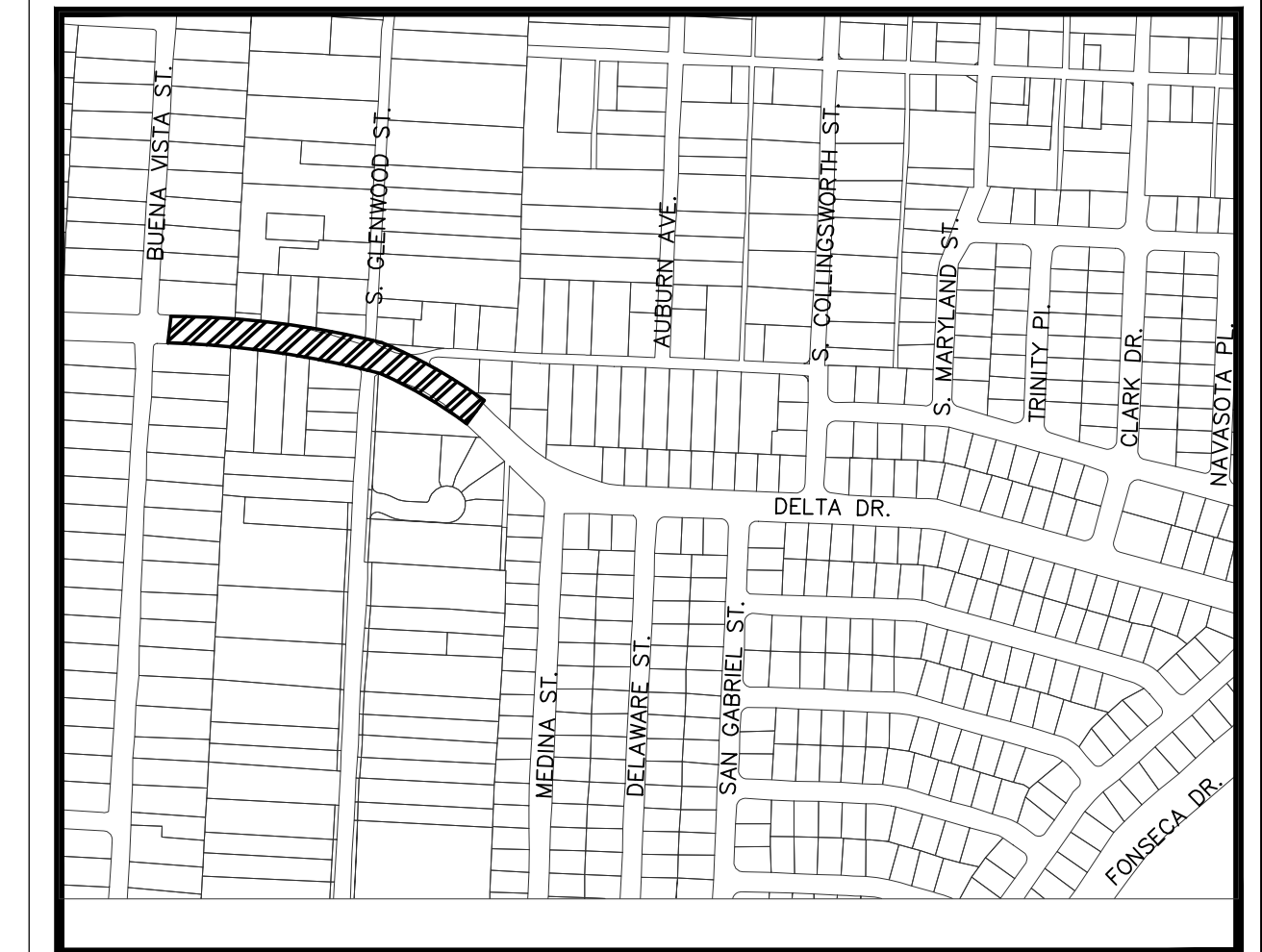

INSET 16
SCALE: 1"=5'

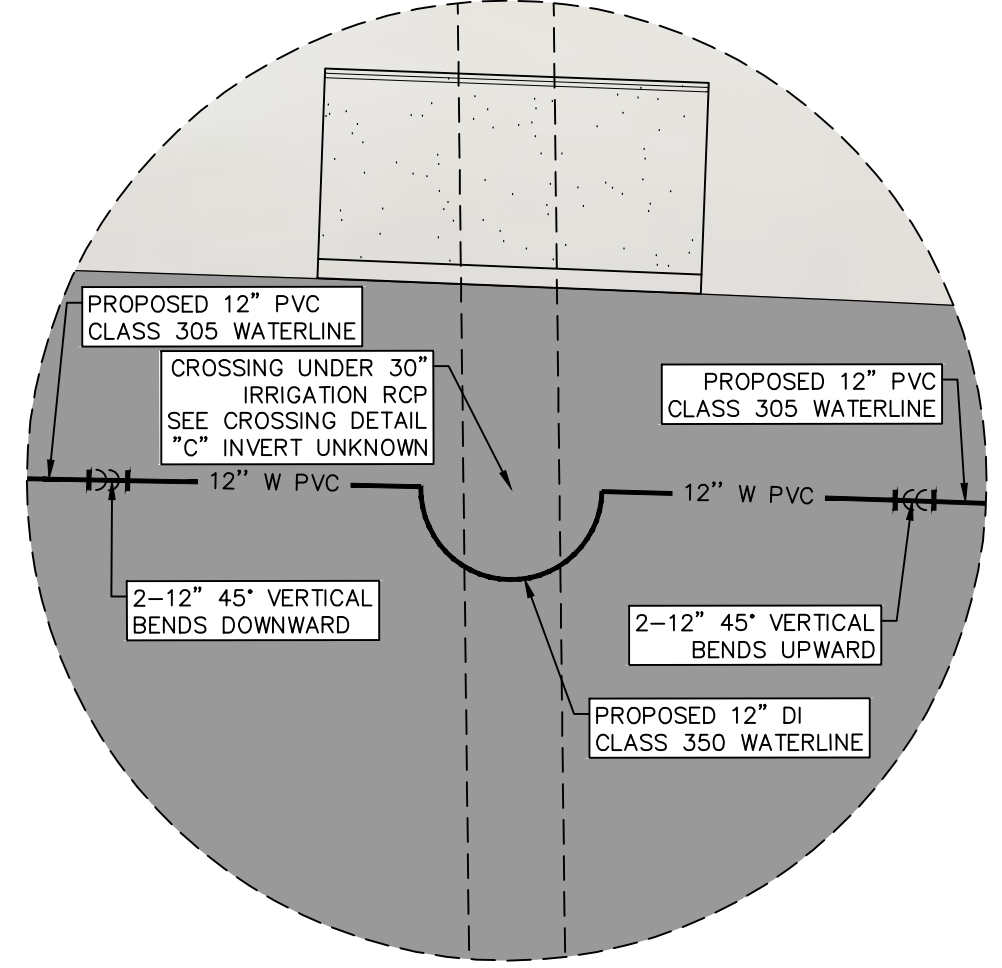

INSET 17
SCALE: 1"=5'

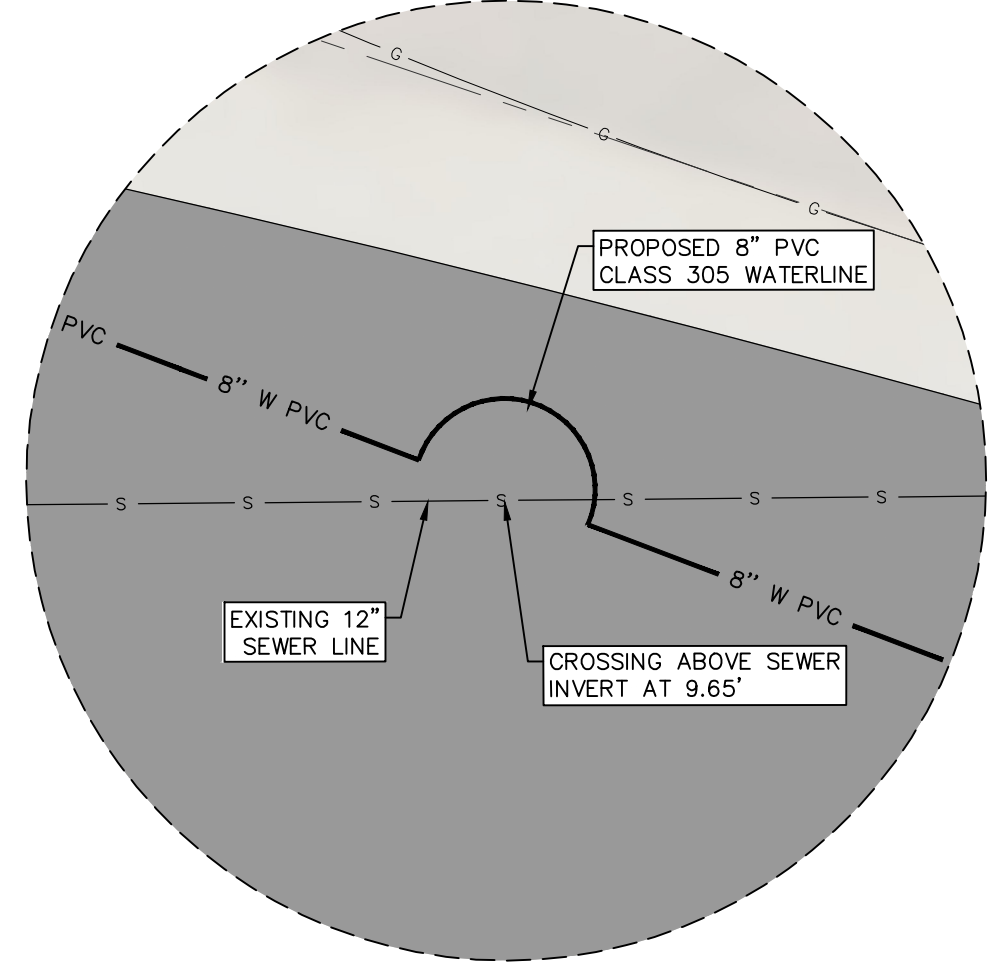

INSET 18
SCALE: 1"=5'

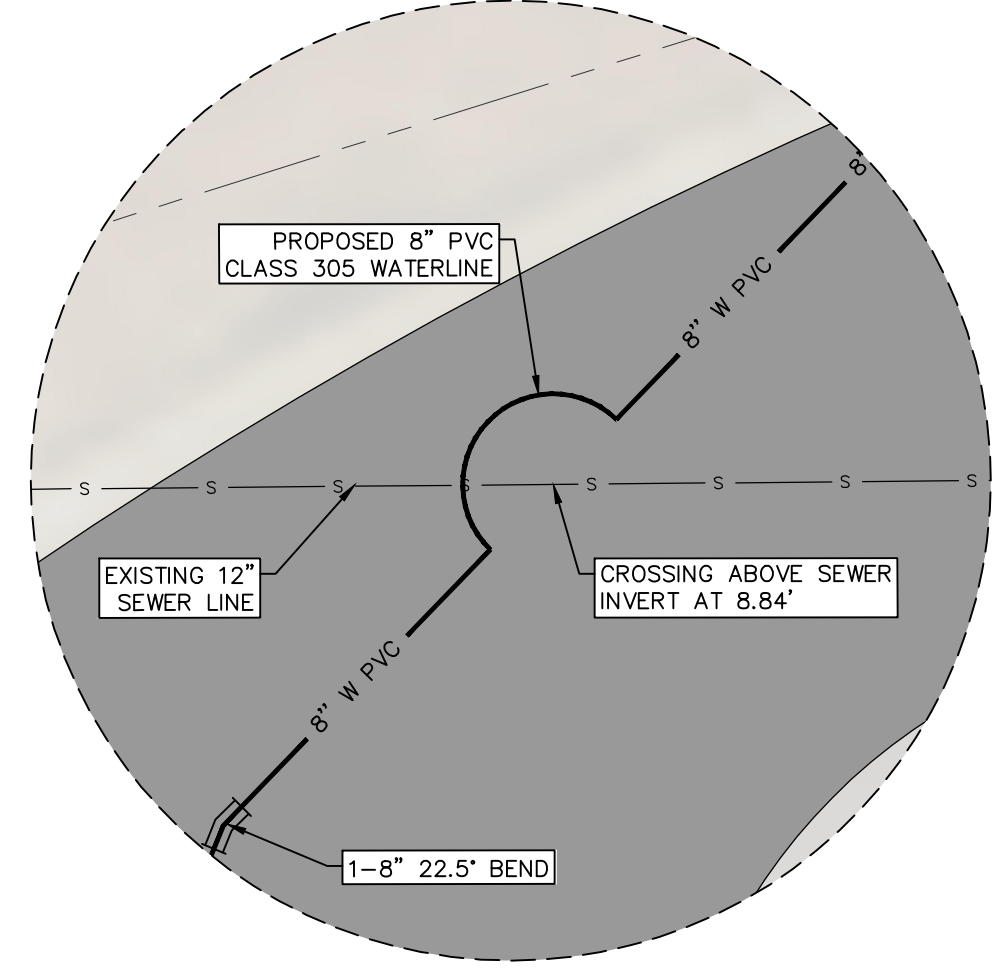

INSET 19
SCALE: 1"=5'

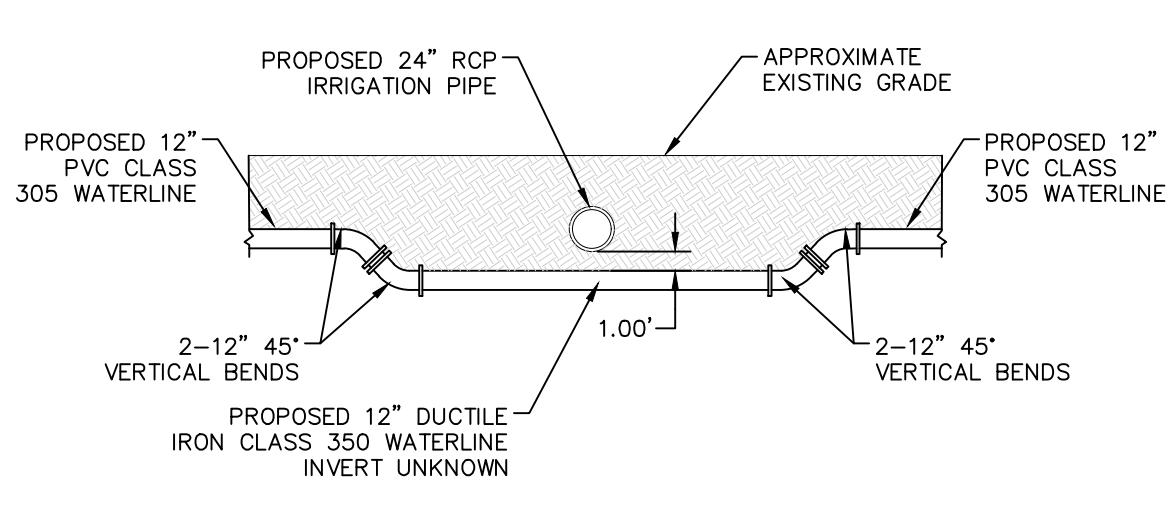

CROSSING DETAIL "B"
SCALE: 1"=10'

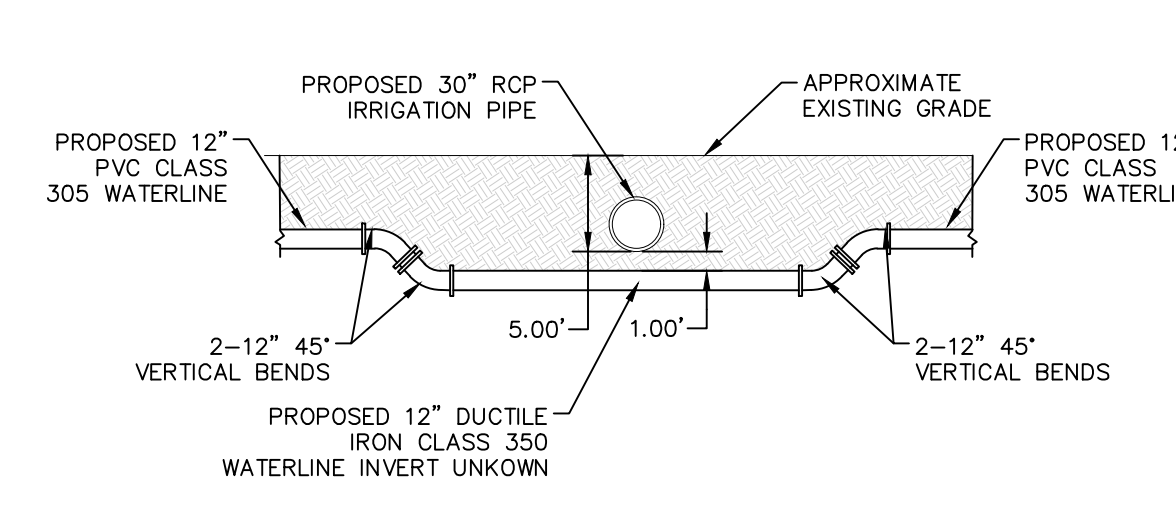

CROSSING DETAIL "C"
SCALE: 1"=10'

LEGEND:

---	SUBDIVISION LINE	[Pattern]	EXISTING CONCRETE
---	RIGHT-OF-WAY LINE	[Pattern]	PROPOSED CONCRETE
---	PROPERTY LINE	[Pattern]	PROPOSED 2" HMAc PAVEMENT
---	CENTER LINE	[Pattern]	EXISTING CURB & GUTTER
UE	EXISTING UNDERGROUND CABLE	[Pattern]	PROPOSED CURB & GUTTER
W	FORCE MAIN PIPE	[Symbol]	EXISTING WATER VALVE
S	EXISTING SANITARY SEWER LINE	[Symbol]	EXISTING SANITARY SEWER MANHOLE
/AB/ //	EXISTING ABANDONED WATER LINE	[Symbol]	EXISTING STORM SEWER MANHOLE
G	EXISTING GAS LINE	[Symbol]	EXISTING TELEPHONE MANHOLE
W	PROPOSED WATER LINE	[Symbol]	EXISTING TELEPHONE BOX
/ // //	EXISTING WATER LINE TO BE ABANDONED	[Symbol]	EXISTING ELECTRIC/TRAFFIC SIGNAL BOX
RW	EXISTING RECLAIMED WATER LINE	[Symbol]	EXISTING PARKING/ROAD SIGN
[Symbol]	REPLACE SERVICE LINE FROM PROPOSED MAIN TO EXISTING METER	[Symbol]	EXISTING GAS VALVE
[Symbol]	REPLACE SERVICE LINE FROM PROPOSED MAIN TO EXISTING METER BY BORING METHOD	[Symbol]	PROPOSED GATE VALVE
[Symbol]	EXISTING SERVICE LINE TO REMAIN UNDISTURBED	[Symbol]	FOUND CHISELED "X" ON CONCRETE
[Symbol]	PROPOSED VERTICAL BENDS		
[Symbol]	EXISTING FIRE HYDRANT		
[Symbol]	PROPOSED FIRE HYDRANT		

STOP!
CALL BEFORE YOU DIG

BROCK & BUSTILLOS INC.
CONSULTING CIVIL ENGINEERS
LAND SURVEYORS

417 EXECUTIVE CENTER
EL PASO, TEXAS 79902
WWW.BROCKBUSTILLOS.COM

PH (915) 542-4900
FAX (915) 542-2867
TBPE Firm Reg. No.: F-737

B&B JOB No.: 05970-046

See Local Authority

HECTOR MARTINEZ
LICENSED PROFESSIONAL ENGINEER
132659

04/11/2022

Designed:	H.M.	Material Size Clarification, Updated Quantities, Updated Dig Texas 811	E.R.	04/07/2022
Drawn:	I.V., E.R.			
Checked:	H.M.			
Approved:	H.M.			
Date:	APRIL 2022			
No.	Revision Description	By	Date	

DELTA DRIVE WATERLINE REPLACEMENT

BUENA VISTA DR TO GLENWOOD ST
FROM STA. 29+00 TO STA. 36+50

Job Number: 05970-046

Sheet Number: 7 OF 17

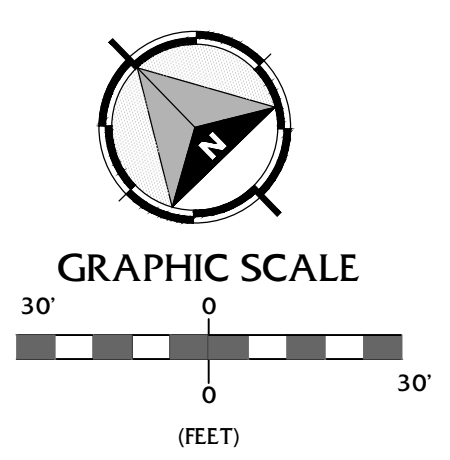
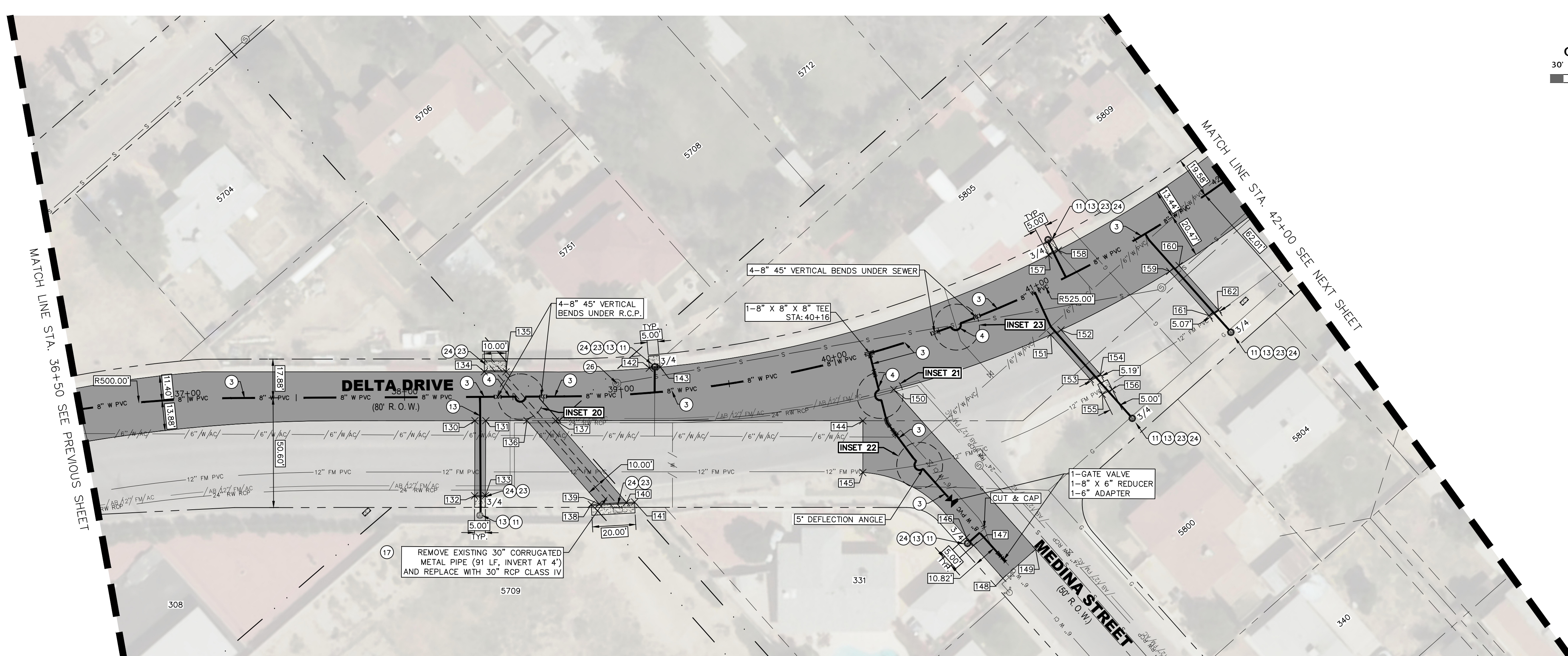

POINT TABLE			POINT TABLE		
POINT #	NORTHING	EASTING	POINT #	NORTHING	EASTING
130	10655881.4355	405868.8799	146	10655685.0796	405994.4318
131	10655877.9607	405872.4753	147	10655680.0843	405994.2197
132	10655856.6678	405844.6953	149	10655658.9022	406013.5110
133	10655853.2071	405848.3043	150	10655757.3502	406017.7439
134	10655894.6253	405887.7364	151	10655725.1852	406087.3788
135	10655887.6705	405894.9219	152	10655723.4572	406092.3099
136	10655864.7585	405886.1345	153	10655697.6856	406086.2113
137	10655855.5607	405895.6478	154	10655696.0779	406091.1475
138	10655816.3266	405880.5747	155	10655688.8673	406085.3907
139	10655813.9203	405883.3622	156	10655687.3029	406090.1940
140	10655805.6641	405892.9268	157	10655752.1929	406112.2271
141	10655803.2579	405895.7143	158	10655750.7572	406117.0166
142	10655842.8418	405943.5739	159	10655707.9557	406147.1159
143	10655839.6943	405947.4589	160	10655706.9118	406152.0761
144	10655756.9481	405997.4840	161	10655680.7117	406145.9593
145	10655739.7862	405980.8562	162	10655679.6597	406150.9191

NEW CONSTRUCTION SUMMARY DELTA DRIVE FROM STA. 36+50 TO 42+00				
NO.	ITEM	STATION	ASBUILT	QUANTITY
3	8" PVC (CLASS 305) WATERLINE			580 LF
4	8" DI (CLASS 350) WATERLINE			80 LF
7	TRENCH SAFETY SYSTEM			660 LF
10	FURNISH AND INSTALL METER BOX AND LID			1 EA
11	3/4" COPPER SERVICE CONNECTIONS			4 EA
13	3/4" COPPER SERVICE LINE			203 LF
16	4-SACK SOIL CEMENT BACKFILL & SUBGRADE			440 SY
17	REMOVE CMP AND REPLACE WITH 30" RCP			91 LF
20	2" HMAc PAVEMENT REPLACEMENT (BRIDGE)			440 SY
21	2" MILL AND OVERLAY EXISTING HMAc BEYOND BRIDGE			1656 SY
23	REMOVE & REPLACE CONCRETE SIDEWALK			200 SF
24	REMOVE & REPLACE CURB & GUTTER			60 LF
26	CONCRETE APRON FOR PAVEMENT PENETRATIONS			1 EA



Key Map Scale: 1"=500'

LEGEND:

---	SUBDIVISION LINE	[Pattern]	EXISTING CONCRETE
---	RIGHT-OF-WAY LINE	[Pattern]	PROPOSED CONCRETE
---	PROPERTY LINE	[Pattern]	PROPOSED 2" HMAc PAVEMENT
---	CENTER LINE	[Pattern]	EXISTING CURB & GUTTER
---	UE	[Pattern]	PROPOSED CURB & GUTTER
---	W	[Symbol]	EXISTING WATER VALVE
---	S	[Symbol]	EXISTING SANITARY SEWER MANHOLE
---	/AB/	[Symbol]	EXISTING ABANDONED WATER LINE
---	G	[Symbol]	EXISTING GAS LINE
---	W	[Symbol]	PROPOSED WATER LINE
---	/W/	[Symbol]	EXISTING WATER LINE TO BE ABANDONED
---	RW	[Symbol]	EXISTING RECLAIMED WATER LINE
---	[Symbol]	[Symbol]	REPLACE SERVICE LINE FROM PROPOSED MAIN TO EXISTING METER
---	[Symbol]	[Symbol]	REPLACE SERVICE LINE FROM PROPOSED MAIN TO EXISTING METER BY BORING METHOD
---	[Symbol]	[Symbol]	EXISTING SERVICE LINE TO REMAIN UNDISTURBED
---	[Symbol]	[Symbol]	PROPOSED VERTICAL BENDS
---	[Symbol]	[Symbol]	EXISTING FIRE HYDRANT
---	[Symbol]	[Symbol]	PROPOSED FIRE HYDRANT
---	[Symbol]	[Symbol]	EXISTING TELEPHONE MANHOLE
---	[Symbol]	[Symbol]	EXISTING TELEPHONE BOX
---	[Symbol]	[Symbol]	EXISTING ELECTRIC/TRAFFIC SIGNAL BOX
---	[Symbol]	[Symbol]	EXISTING PARKING/ROAD SIGN
---	[Symbol]	[Symbol]	EXISTING GAS VALVE
---	[Symbol]	[Symbol]	PROPOSED GATE VALVE
---	[Symbol]	[Symbol]	FOUND CHISELED "X" ON CONCRETE

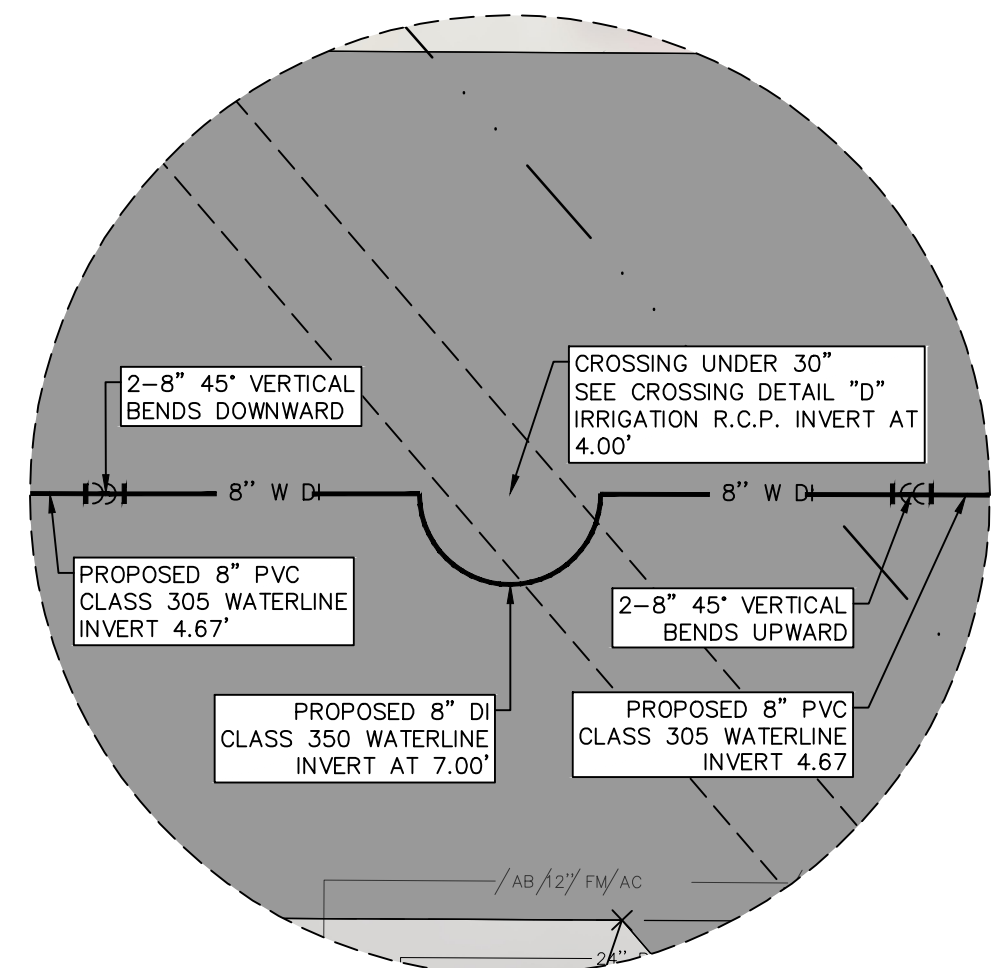

INSET 20 SCALE: 1"=5'

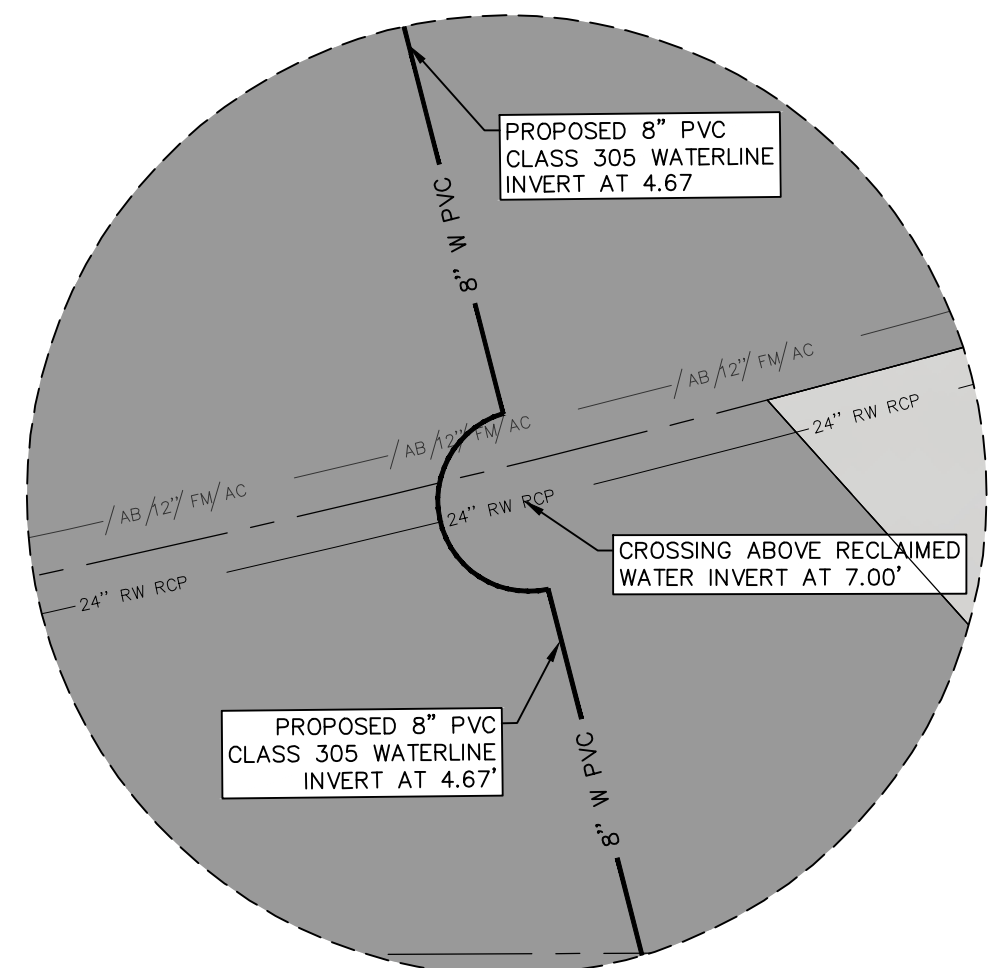

INSET 21 SCALE: 1"=5'

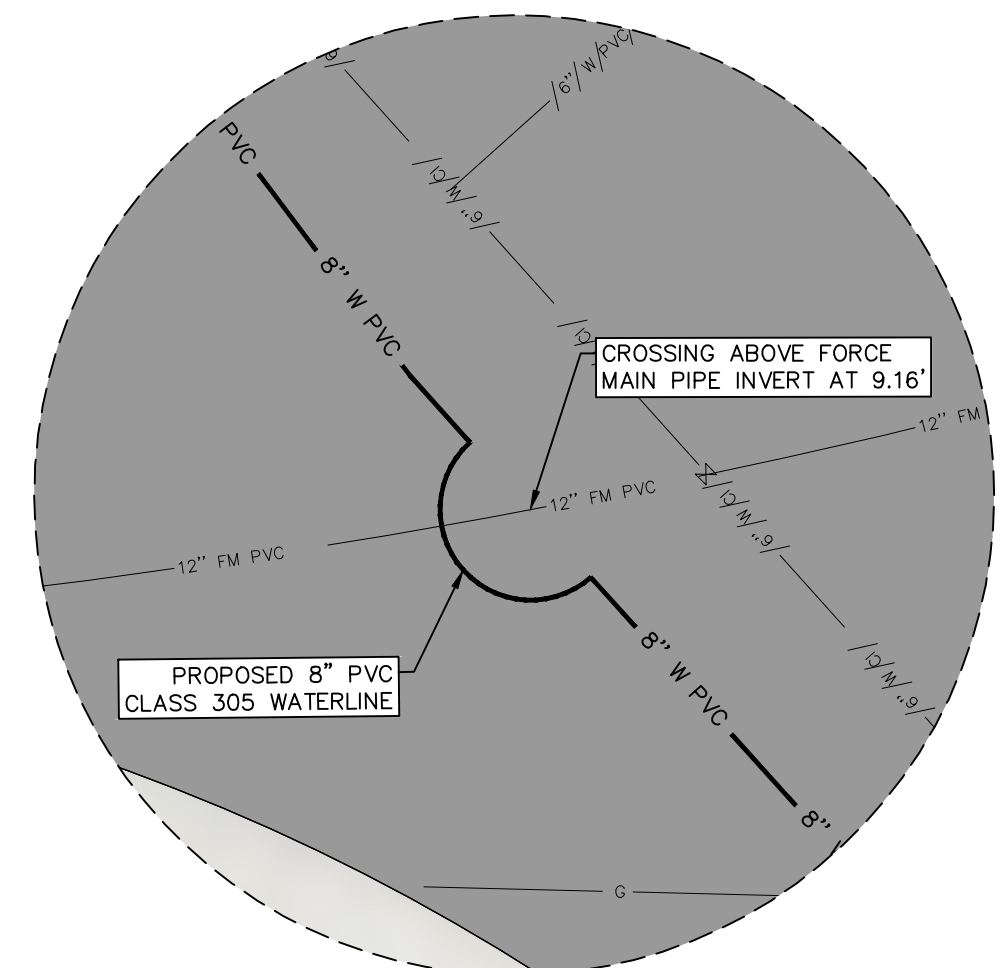

INSET 22 SCALE: 1"=5'

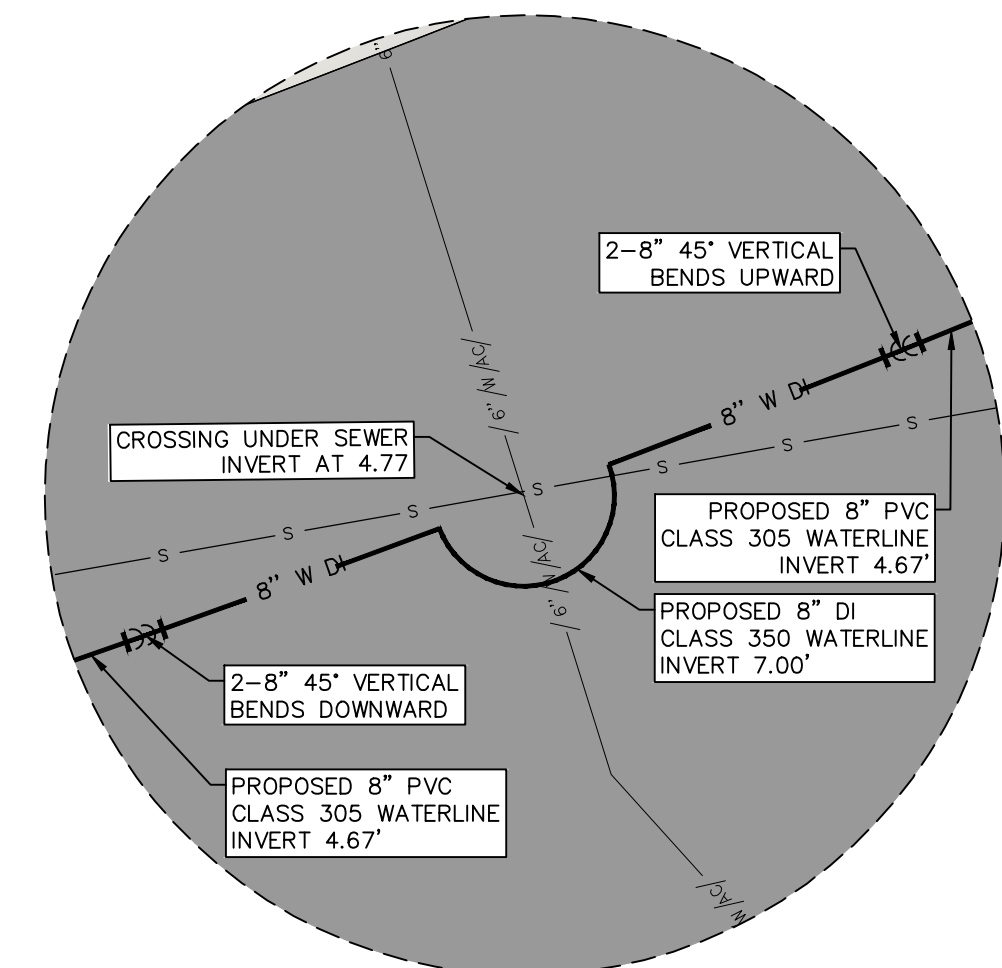

INSET 23 SCALE: 1"=5'

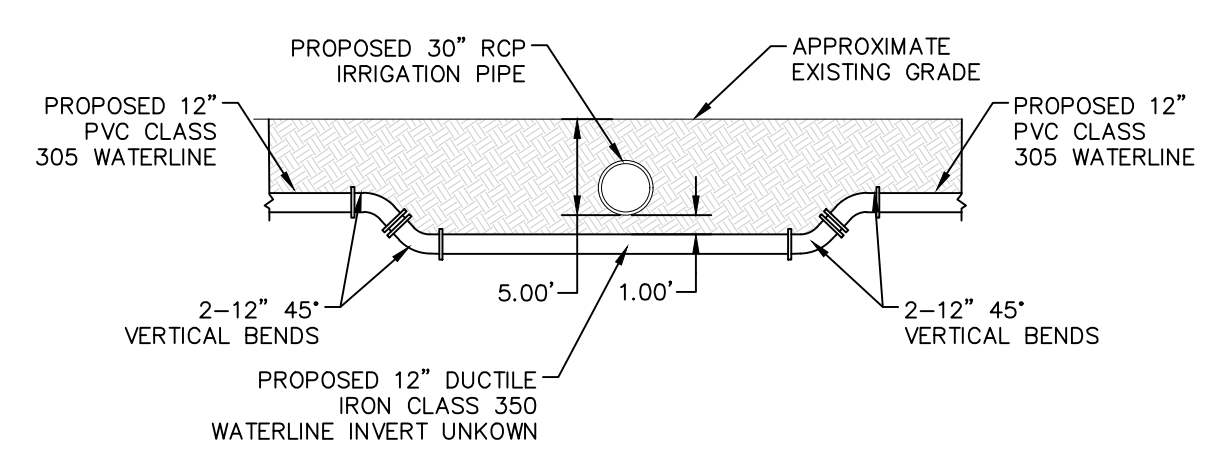

CROSSING DETAIL "D" SCALE: 1"=10'



BROCK & BUSTILLOS INC.
CONSULTING CIVIL ENGINEERS
LAND SURVEYORS

417 EXECUTIVE CENTER
EL PASO, TEXAS 79902
WWW.BROCK&BUSTILLOS.COM

PH (915) 542-4900
FAX (915) 542-2867
TBPE Firm Reg. No.: F-737

B&B JOB No.: 05970-046



Designed:	H.M.	Material Size Clarification, Updated Quantities, Updated Dig Texas 811	E.R.	04/07/2022
Drawn:	I.V., E.R.			
Checked:	H.M.			
Approved:	H.M.			
Date:	APRIL 2022			
No.	Revision Description	By	Date	

DELTA DRIVE WATERLINE REPLACEMENT
GLENWOOD STREET TO MEDINA STREET
FROM STA. 36+50 TO STA. 42+00

Job Number: 05970-046
Sheet Number: 8 OF 17

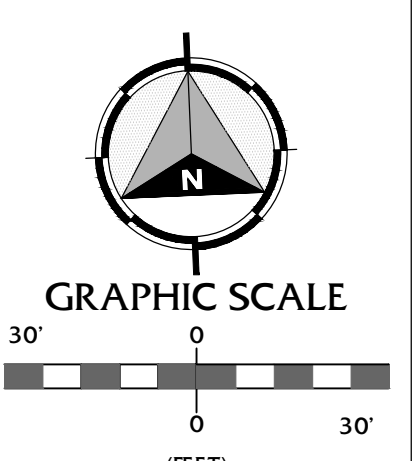
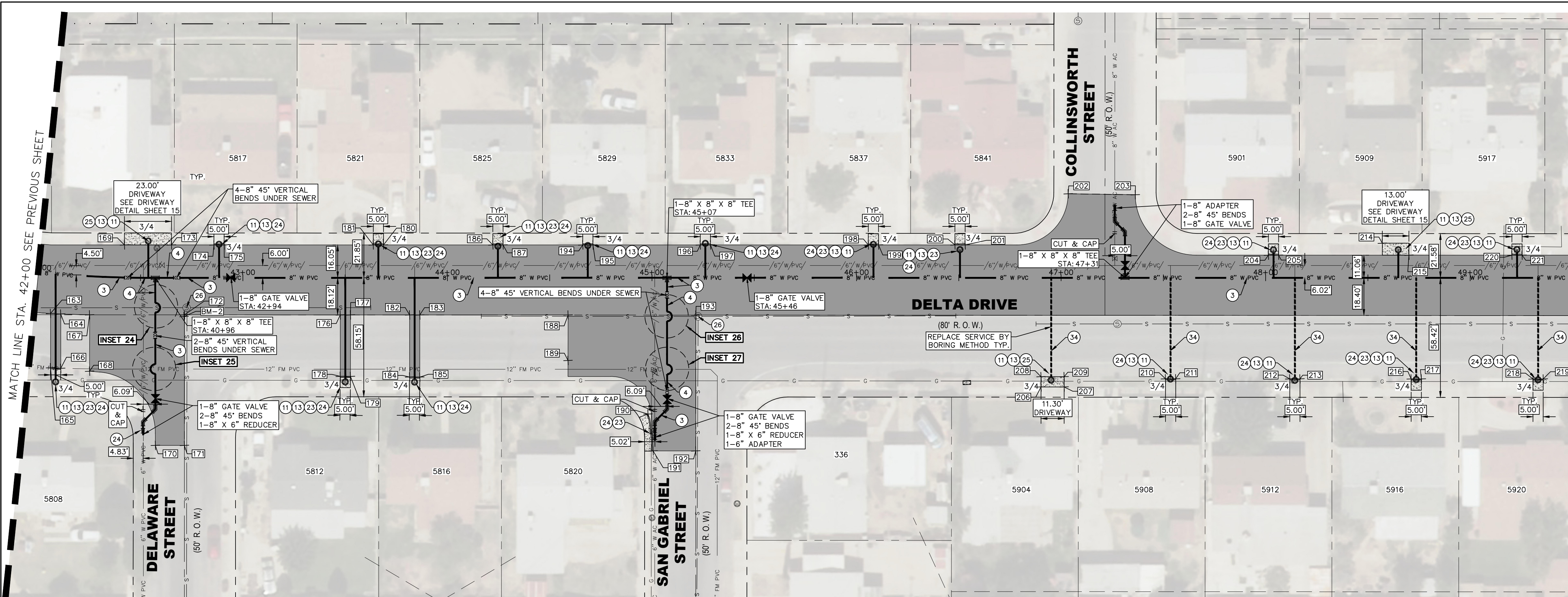

POINT TABLE			POINT TABLE			POINT TABLE		
POINT #	NORTHING	EASTING	POINT #	NORTHING	EASTING	POINT #	NORTHING	EASTING
163	10655699.7396	406199.9671	183	10655691.3788	406380.3065	203	10655735.2180	406732.2623
164	10655699.2843	406204.9523	184	10655661.3102	406374.0250	204	10655702.9584	406796.0261
165	10655673.2981	406198.8445	185	10655661.0524	406379.0185	205	10655702.7462	406801.0216
166	10655672.7700	406203.8266	186	10655724.0430	406417.4300	206	10655643.3671	406882.2412
167	10655698.3108	406219.0240	187	10655723.8309	406422.4255	207	10655642.8875	406933.5330
168	10655670.7767	406217.8511	188	10655668.2634	406452.7178	208	10655648.3626	406982.4534
169	10655731.6867	406237.4794	189	10655666.0910	406451.7605	209	10655647.8830	406993.7451
170	10655633.2241	406248.4396	190	10655638.2879	406489.7005	210	10655644.7462	406743.1758
171	10655632.6140	406262.6277	191	10655620.1716	406491.4179	211	10655644.5315	406748.1713
172	10655696.3187	406265.3667	192	10655619.2852	406512.2856	212	10655642.1349	406803.9093
173	10655730.7099	406260.4623	193	10655685.5797	406515.3601	213	10655641.9202	406808.9049
174	10655729.8282	406281.2220	194	10655722.1783	406461.3336	214	10655706.4515	406851.9180
175	10655729.6160	406286.2175	195	10655719.9661	406466.3291	215	10655700.0436	406864.6542
176	10655693.0478	406341.4420	196	10655719.7404	406518.7331	216	10655639.5874	406863.1922
177	10655692.8330	406346.4374	197	10655719.5282	406523.7286	217	10655639.3726	406868.1872
178	10655663.0579	406340.1688	198	10655716.0412	406605.8279	218	10655637.0285	406922.7057
179	10655662.8001	406345.1623	199	10655714.4570	406643.1274	219	10655636.8124	406927.7018
180	10655726.3123	406364.0013	200	10655714.2448	406648.1229	220	10655697.9079	406914.9366
181	10655726.5245	406359.0058	201	10655714.2448	406648.1229	221	10655697.8957	406919.9321
182	10655691.5916	406375.3111	202	10655737.0721	406699.5021	222	10655695.4800	406265.1300

NEW CONSTRUCTION SUMMARY
DELTA DRIVE FROM STA. 42+00 TO 49+50

NO.	ITEM	STATION	ASBUILT	QUANTITY
3	8" PVC (CLASS 305) WATERLINE		858	LF
4	8" DI (CLASS 350) WATERLINE		106	LF
7	TRENCH SAFETY SYSTEM		964	LF
10	FURNISH AND INSTALL METER BOX AND LID		4	EA
11	3/4" COPPER SERVICE CONNECTIONS		19	EA
13	3/4" COPPER SERVICE LINE		331	LF
16	4-SACK SOIL CEMENT BACKFILL & SUBGRADE		643	SY
20	2" HMAC PAVEMENT REPLACEMENT (BRIDGE)		643	SY
21	2" MILL AND OVERLAY EXISTING HMAC BEYOND BRIDGE		2776	SY
23	REMOVE & REPLACE CONCRETE SIDEWALK		286	SF
24	REMOVE & REPLACE CURB & GUTTER		95	LF
25	REMOVE & REPLACE CONCRETE DRIVEWAY		268	SF
26	CONCRETE APRON FOR PAVEMENT PENETRATIONS		1	EA
34	3/4" COPPER SERVICE LINE BY BORING METHOD		242	LF

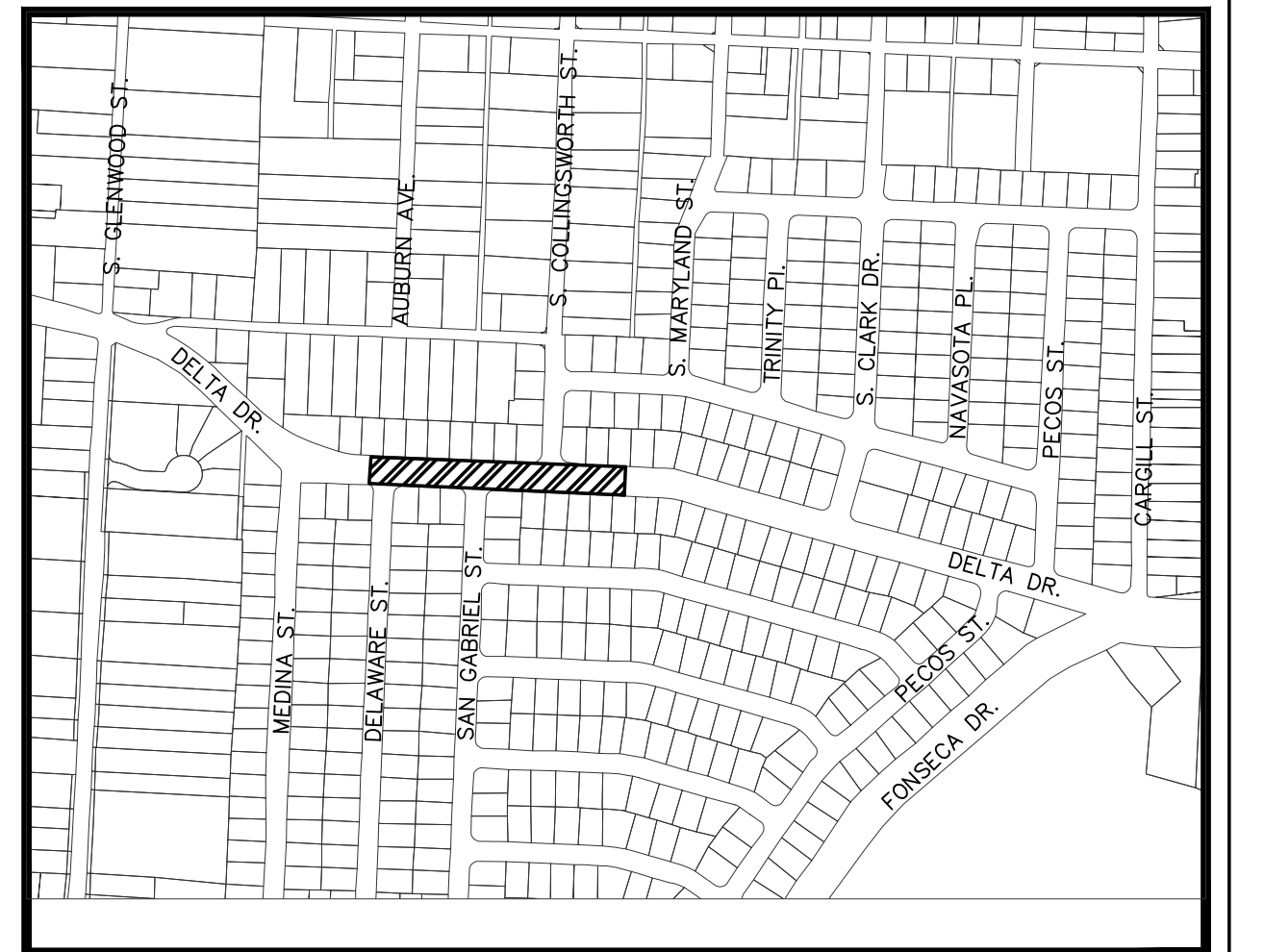

Key Map Scale: 1"=500'

LEGEND:

---	SUBDIVISION LINE	[Pattern]	EXISTING CONCRETE
---	RIGHT-OF-WAY LINE	[Pattern]	PROPOSED CONCRETE
---	PROPERTY LINE	[Pattern]	PROPOSED 2" HMAC PAVEMENT
---	CENTER LINE	[Pattern]	EXISTING CURB & GUTTER
UE	EXISTING UNDERGROUND CABLE	[Pattern]	PROPOSED CURB & GUTTER
W	FORCE MAIN PIPE	[Symbol]	EXISTING WATER VALVE
S	EXISTING SANITARY SEWER LINE	[Symbol]	EXISTING SANITARY SEWER MANHOLE
/-/-	EXISTING ABANDONED WATER LINE	[Symbol]	EXISTING STORM SEWER MANHOLE
G	EXISTING GAS LINE	[Symbol]	EXISTING TELEPHONE MANHOLE
W	PROPOSED WATER LINE	[Symbol]	EXISTING TELEPHONE BOX
/-/-	EXISTING WATER LINE TO BE ABANDONED	[Symbol]	EXISTING ELECTRIC/TRAFFIC SIGNAL BOX
RW	EXISTING RECLAIMED WATER LINE	[Symbol]	EXISTING PARKING/ROAD SIGN
[Symbol]	REPLACE SERVICE LINE FROM PROPOSED MAIN TO EXISTING METER	[Symbol]	EXISTING GAS VALVE
[Symbol]	REPLACE SERVICE LINE FROM PROPOSED MAIN TO EXISTING METER BY BORING METHOD	[Symbol]	PROPOSED GATE VALVE
[Symbol]	EXISTING SERVICE LINE TO REMAIN UNDISTURBED	[Symbol]	FOUND CHISELED "X" ON CONCRETE
[Symbol]	PROPOSED VERTICAL BENDS		
[Symbol]	EXISTING FIRE HYDRANT		
[Symbol]	PROPOSED FIRE HYDRANT		

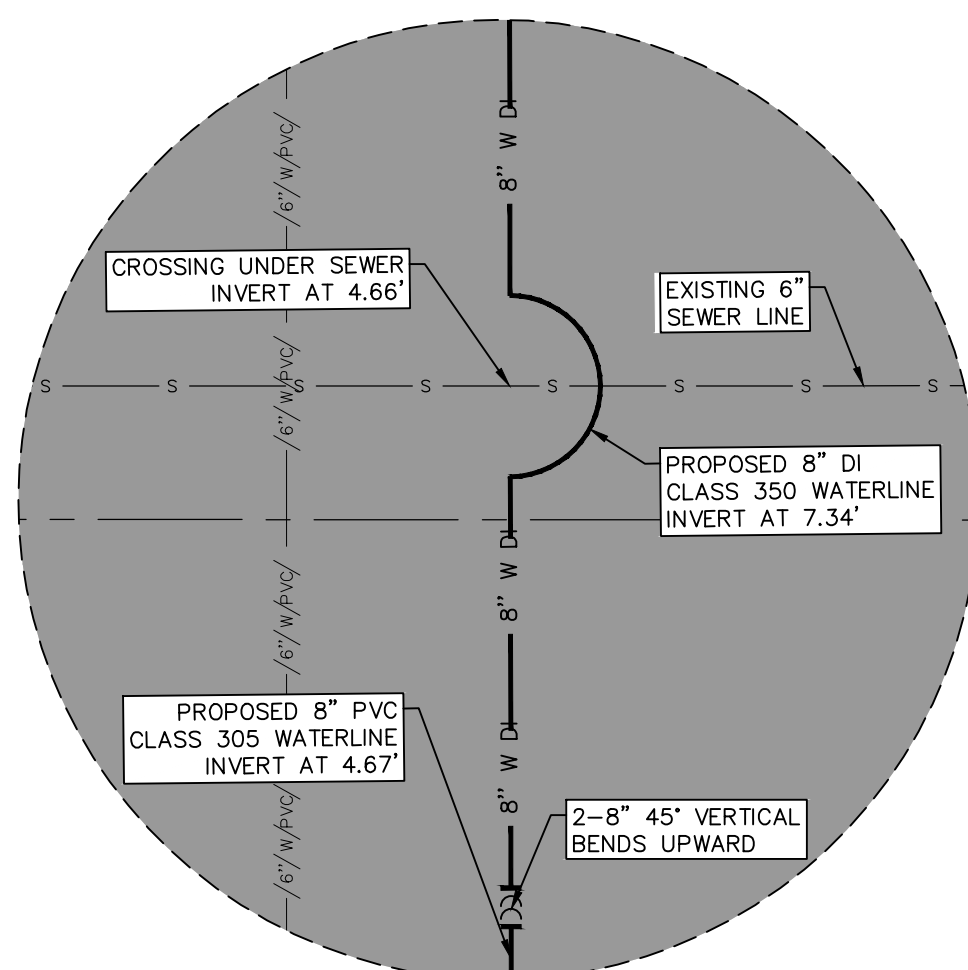

INSET 24 SCALE: 1"=5'

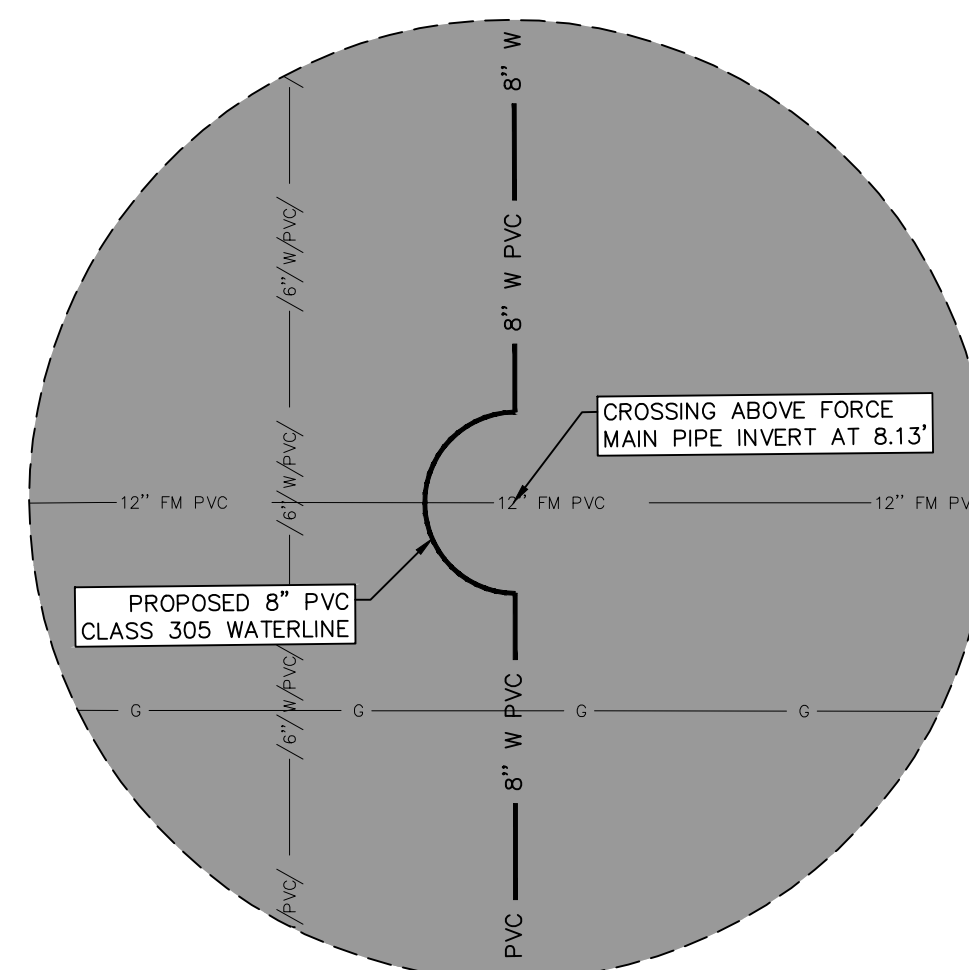

INSET 25 SCALE: 1"=5'

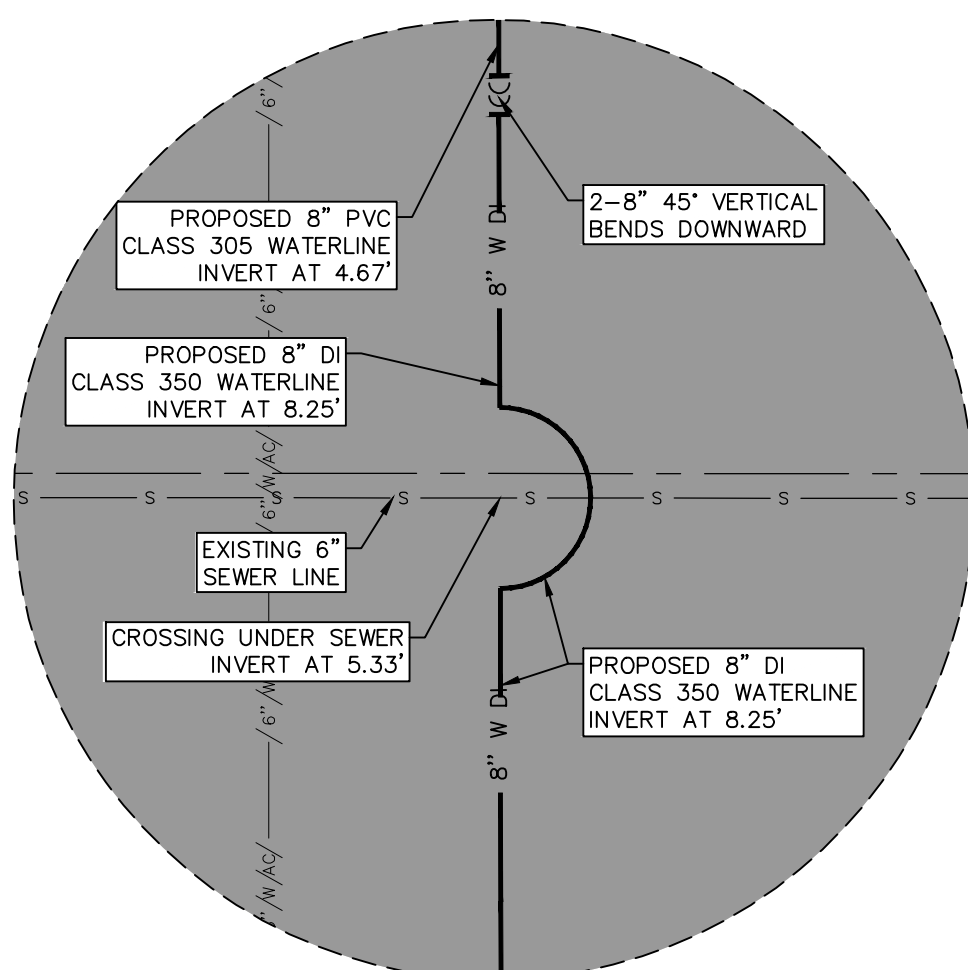

INSET 26 SCALE: 1"=5'

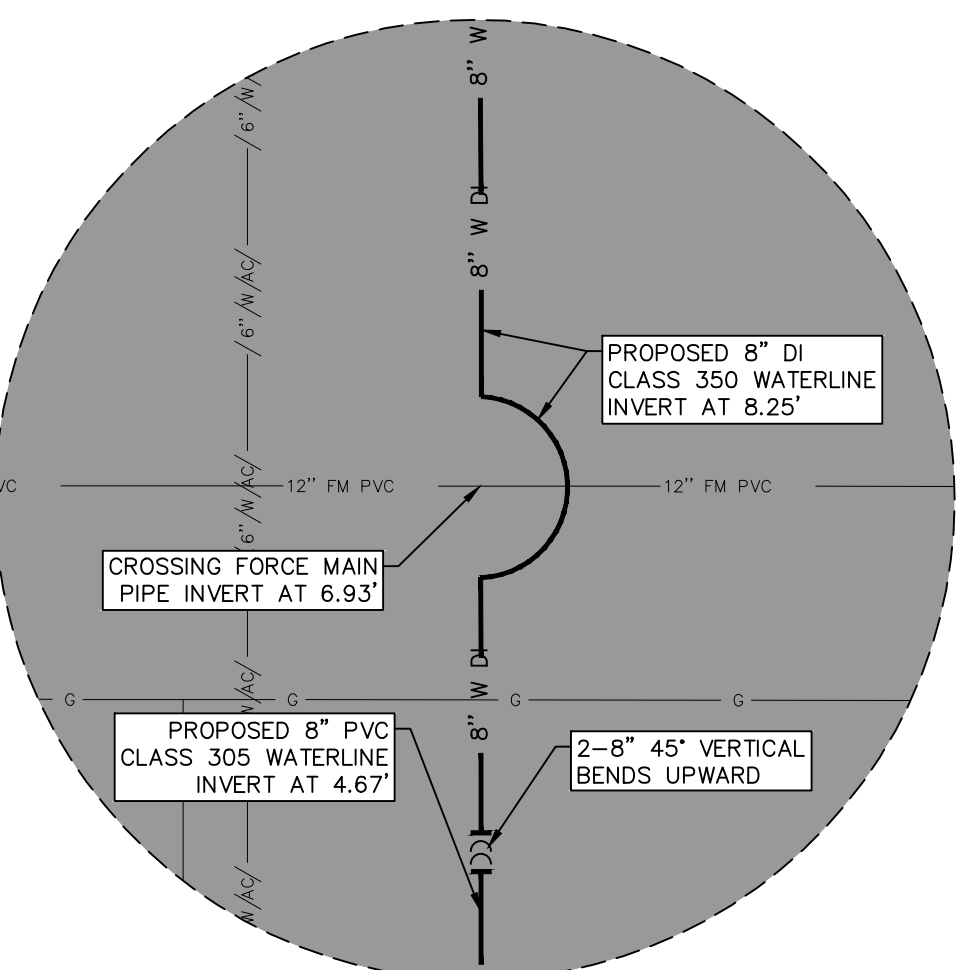

INSET 27 SCALE: 1"=5'



BROCK & BUSTILLOS INC.
CONSULTING CIVIL ENGINEERS
LAND SURVEYORS
417 EXECUTIVE CENTER
EL PASO, TEXAS 79902
WWW.BROCK&BUSTILLOS.COM
PH (915) 542-4900
FAX (915) 542-2867
TBPE Firm Reg. No.: F-737
B&B JOB No.: 05970-046

Nector Martinez
HECTOR MARTINEZ
132659
LICENSED PROFESSIONAL ENGINEER

el paso WATER

Designed:	H.M.	Material Size Clarification, Updated Quantities, Updated Dig Texas 811	E.R.	04/07/2022
Drawn:	I.V., E.R.			
Checked:	H.M.			
Approved:	H.M.			
Date:	APRIL 2022			
No.	Revision Description	By	Date	

DELTA DRIVE WATERLINE REPLACEMENT
DELaware ST TO COLLINSWORTH ST
FROM STA. 42+00 TO STA. 49+50

Job Number: 05970-046
Sheet Number: 9 OF 17

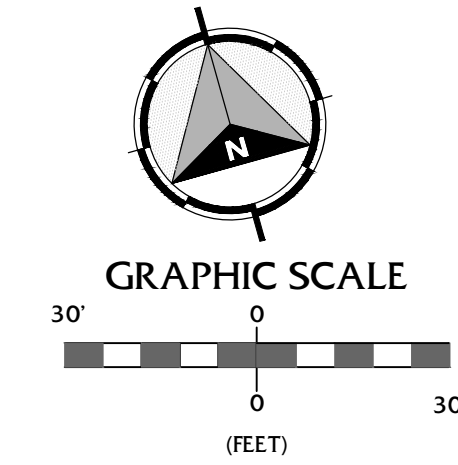

POINT #	NORTHING	EASTING
270	10655455.2745	407675.9937
271	10655453.9141	407680.7247
272	10655513.9150	407691.7122
273	10655513.0593	407696.6637
274	10655502.0842	407734.3280
275	10655500.7468	407739.1458
276	10655433.7401	407752.6785
277	10655432.4026	407757.4965
278	10655486.2655	407791.3090
279	10655484.9280	407796.1268
280	10655470.6482	407847.5643
281	10655469.3108	407852.3821
282	10655430.9941	407878.3368
283	10655398.3367	407869.2706
284	10655362.7843	407865.4744
285	10655357.2971	407905.2396
286	10655418.7300	407922.3287
287	10655454.4379	407905.9560
288	10655453.1004	407910.7738
289	10655438.7227	407962.5641

NEW CONSTRUCTION SUMMARY DELTA DRIVE FROM STA. 57+00 TO 64+68				
NO.	ITEM	STATION	ASBUILT	QUANTITY
3	8" PVC (CLASS 305) WATERLINE		852	LF
4	8" DI (CLASS 350) WATERLINE		69	LF
7	TRENCH SAFETY SYSTEM		921	LF
10	FURNISH AND INSTALL METER BOX AND LID		2	EA
11	3/4" COPPER SERVICE CONNECTIONS		9	EA
13	3/4" COPPER SERVICE LINE		72	LF
16	4-SACK SOIL CEMENT BACKFILL & SUBGRADE		614	SY
20	2" HMAC PAVEMENT REPLACEMENT (BRIDGE)		614	SY
21	2" MILL AND OVERLAY EXISTING HMAC BEYOND BRIDGE		2632	SY
23	REMOVE & REPLACE CONCRETE SIDEWALK		304	SF
24	REMOVE & REPLACE CURB & GUTTER		74	LF
26	CONCRETE APRON FOR PAVEMENT PENETRATIONS		2	EA
34	3/4" COPPER SERVICE LINE BY BORING METHOD		150	LF

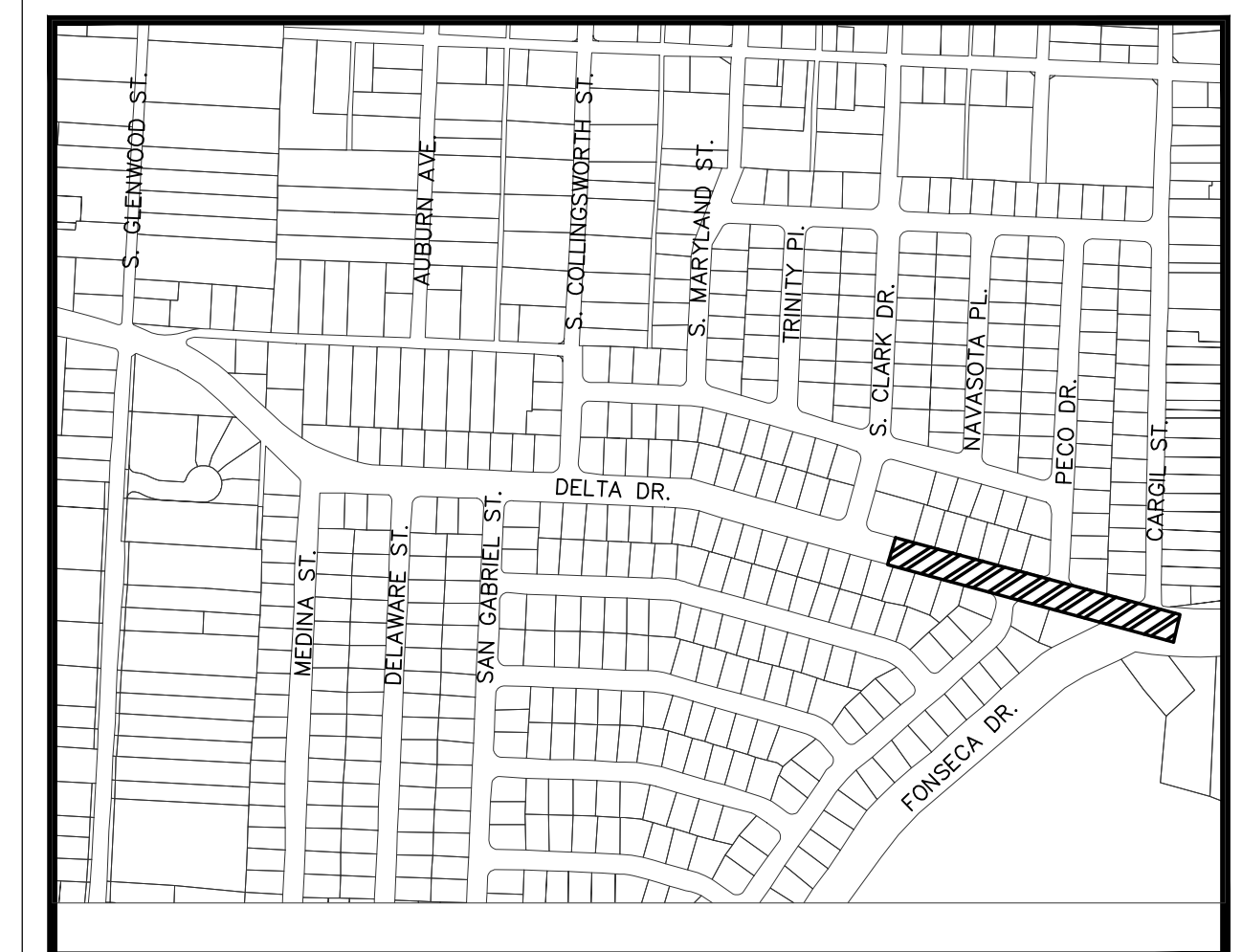

LEGEND:	
---	SUBDIVISION LINE
---	RIGHT-OF-WAY LINE
---	PROPERTY LINE
---	CENTER LINE
---	EXISTING UNDERGROUND CABLE
---	FORCE MAIN PIPE
---	EXISTING SANITARY SEWER LINE
---	EXISTING ABANDONED WATER LINE
---	EXISTING GAS LINE
---	PROPOSED WATER LINE
---	EXISTING WATER LINE TO BE ABANDONED
---	EXISTING RECLAIMED WATER LINE
---	REPLACE SERVICE LINE FROM PROPOSED MAIN TO EXISTING METER
---	REPLACE SERVICE LINE FROM PROPOSED MAIN TO EXISTING METER BY BORING METHOD
---	EXISTING SERVICE LINE TO REMAIN UNDISTURBED
---	PROPOSED VERTICAL BENDS
---	EXISTING FIRE HYDRANT
---	PROPOSED FIRE HYDRANT
---	EXISTING CONCRETE
---	PROPOSED CONCRETE
---	PROPOSED 2" HMAC PAVEMENT
---	EXISTING CURB & GUTTER
---	PROPOSED CURB & GUTTER
---	EXISTING WATER VALVE
---	EXISTING SANITARY SEWER MANHOLE
---	EXISTING STORM SEWER MANHOLE
---	EXISTING TELEPHONE MANHOLE
---	EXISTING TELEPHONE BOX
---	EXISTING ELECTRIC/TRAFFIC SIGNAL BOX
---	EXISTING PARKING/ROAD SIGN
---	EXISTING GAS VALVE
---	PROPOSED GATE VALVE
---	FOUND CHISELED "X" ON CONCRETE

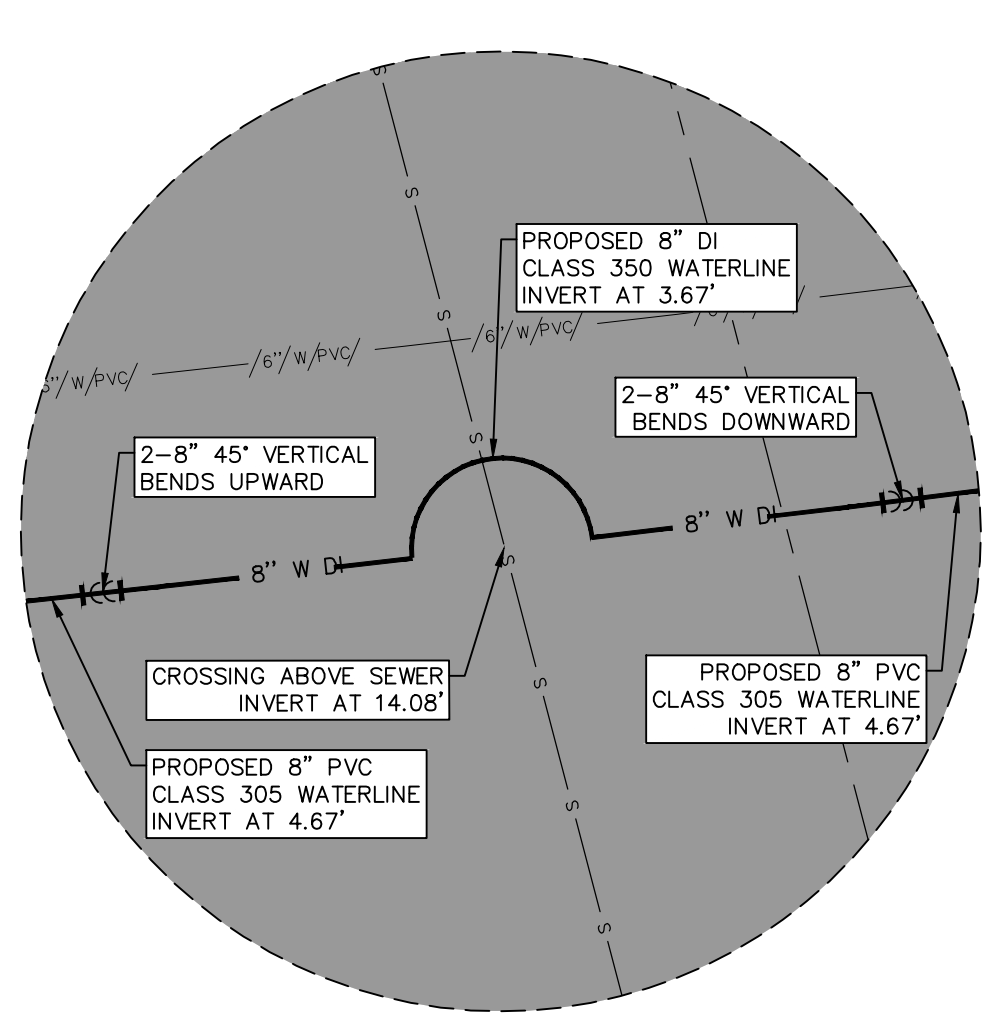
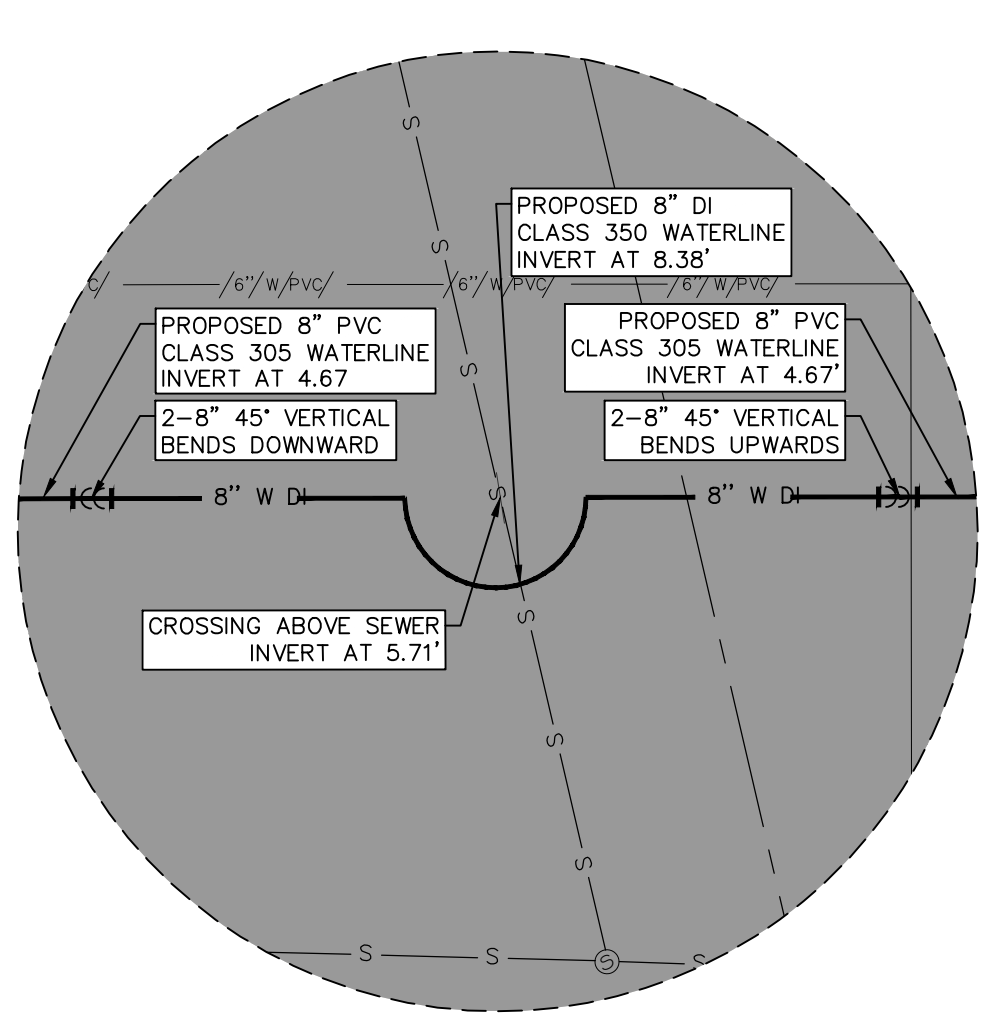
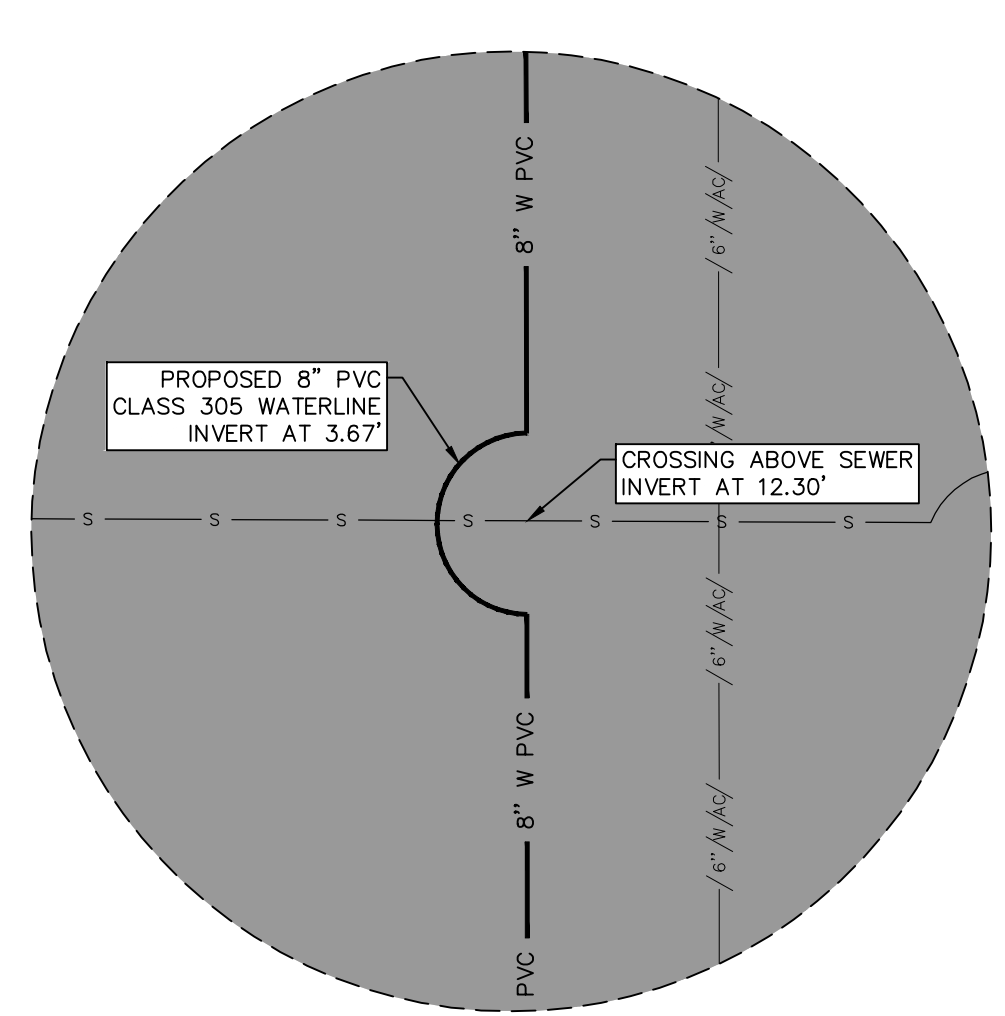
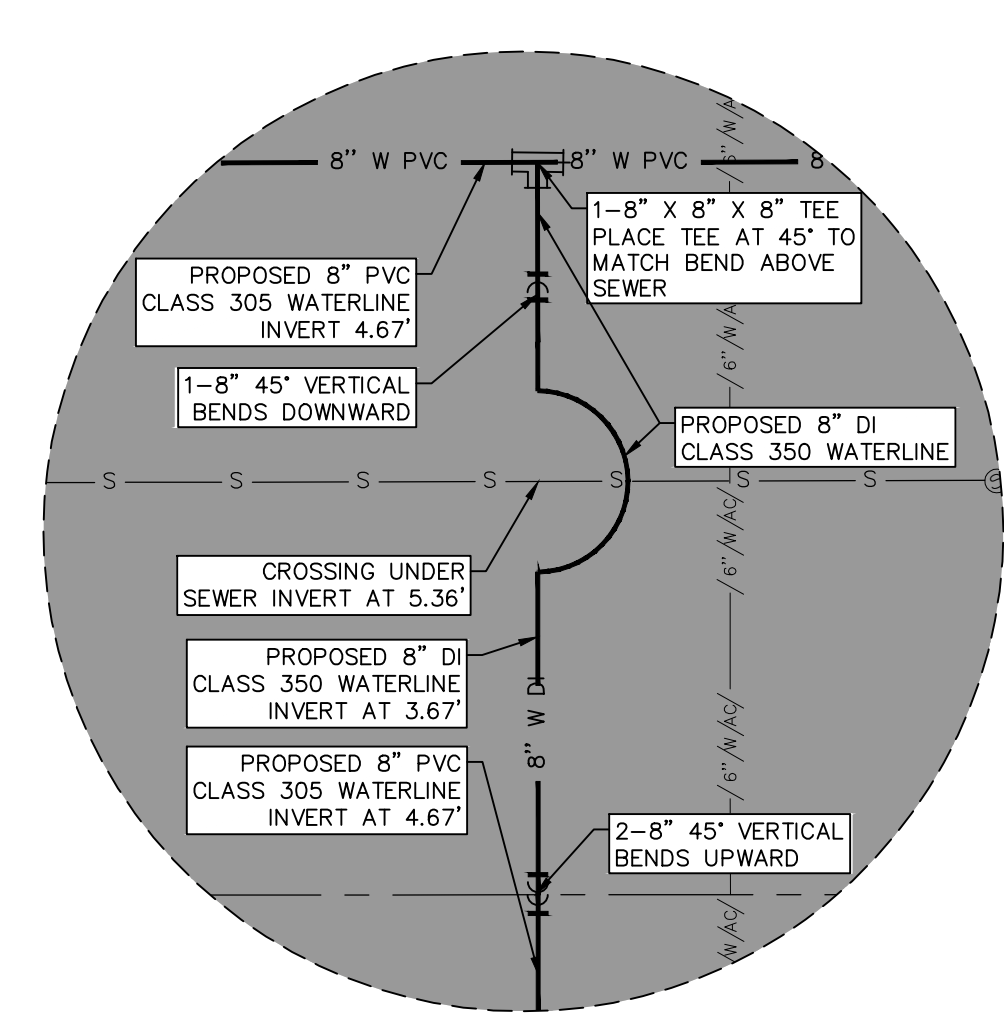
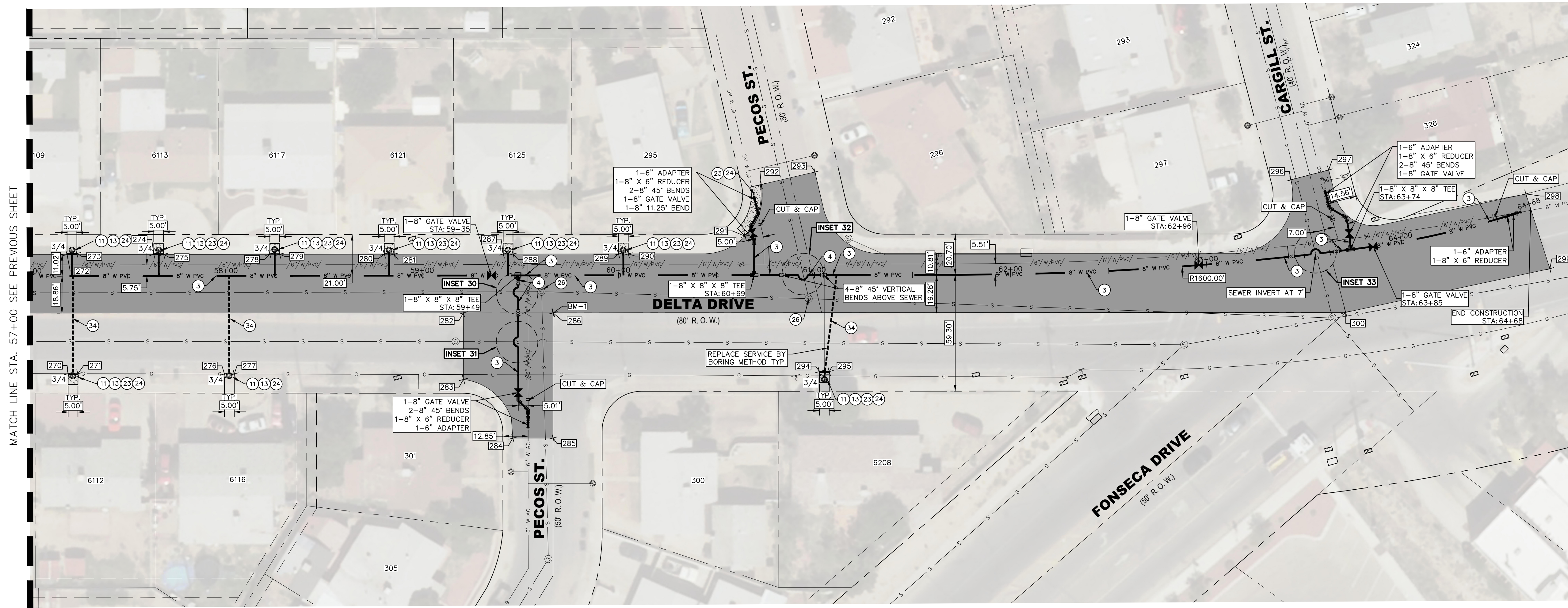

BROCK & BUSTILLOS INC.
CONSULTING CIVIL ENGINEERS
LAND SURVEYORS
417 EXECUTIVE CENTER
EL PASO, TEXAS 79902
WWW.BROCK&BUSTILLOS.COM
PH (915) 542-4900
FAX (915) 542-2867
TBPE Firm Reg. No.: F-737
B&B JOB No.: 05970-046

Hector Martinez
HECTOR MARTINEZ
132659
LICENSED PROFESSIONAL ENGINEER
04/11/2022

el paso WATER

Designed:	H.M.	MATERIAL SIZE CLARIFICATION, UPDATED QUANTITIES, UPDATED DIG TEXAS 811	E.R.	04/07/2022
Drawn:	I.V., E.R.			
Checked:	H.M.			
Approved:	H.M.			
Date:	APRIL 2022			
No.	Revision Description	By	Date	

DELTA DRIVE WATERLINE REPLACEMENT
Job Number: 05970-046
Sheet Number: 11 OF 17
S. CLARK DR TO CARGILL ST FROM STA. 57+00 TO STA. 64+68